

**NextEra Energy
Diadromous Fish Passage Report
for the
Lower Kennebec River Watershed
during the 2008 Migration Season**

**NextEra Energy Maine Operating Services, LLC
160 Capital Street, Suite 8
Augusta, Maine 04330**

May 15, 2009

Table of Contents

| | <u>PAGE</u> |
|---|-------------|
| 1.0 EXECUTIVE SUMMARY | 1 |
| 2.0 UPSTREAM ANADROMOUS FISH PASSAGE | 1 |
| 2.1 METHODS | 1 |
| 2.1.1 Fort Halifax | 1 |
| 2.1.1.1 Fish Pump | 2 |
| 2.1.2 Lockwood | 3 |
| 2.1.2.1 Fish Lift..... | 4 |
| 2.1.2.2 Visual Observations | 4 |
| 2.1.3 Shawmut | 5 |
| 2.1.4 Weston | 5 |
| 2.2 RESULTS..... | 5 |
| 2.2.1 Fort Halifax..... | 5 |
| 2.2.1.1 River Herring | 5 |
| 2.2.1.2 American Shad..... | 8 |
| 2.2.1.3 Atlantic Salmon | 8 |
| 2.2.1.4 Non-Target Fish Species..... | 8 |
| 2.2.2 Lockwood | 8 |
| 2.2.2.1 River Herring | 9 |
| 2.2.2.2 American Shad..... | 12 |
| 2.2.2.3 Atlantic Salmon | 12 |
| 2.2.2.4 Non-Target Fish Species..... | 14 |
| 2.3 DISCUSSION AND FUTURE PLANS | 15 |
| 2.3.1 Fort Halifax..... | 15 |
| 2.3.1.1 Fish Pump | 15 |
| 2.3.2 Lockwood | 15 |
| 2.3.2.1 River Herring, American Shad and Atlantic Salmon..... | 15 |
| 2.3.2.2 Fish Lift..... | 15 |
| 2.3.2.3 Proposed American Shad Upstream Passage Radio Telemetry Study | 16 |
| 2.3.2.4 Proposed Hydraulic Study of Flows in and Around the Fish Lift | 17 |
| 2.3.3 Shawmut | 18 |
| 2.3.4 Weston | 18 |
| 3.0 UPSTREAM EEL PASSAGE | 18 |
| 3.1 INTRODUCTION..... | 18 |
| 3.2 METHODS | 18 |
| 3.2.1 Fort Halifax..... | 18 |
| 3.2.2 Lockwood | 19 |
| 3.2.3 Shawmut | 19 |
| 3.2.4 Weston | 19 |
| 3.3 RESULTS..... | 19 |
| 3.3.1 Fort Halifax..... | 19 |
| 3.3.2 Lockwood | 20 |
| 3.3.3 Shawmut | 20 |

| | | |
|------------|--|-----------|
| 3.3.4 | Weston | 20 |
| 3.4 | DISCUSSION AND FUTURE PLANS | 21 |
| 3.4.1 | Fort Halifax | 21 |
| 3.4.2 | Lockwood | 21 |
| 3.4.3 | Shawmut | 21 |
| 3.4.4 | Weston | 21 |
| 4.0 | DOWNSTREAM ANADROMOUS FISH PASSAGE..... | 21 |
| 4.1 | INTRODUCTION..... | 21 |
| 4.2 | METHODS..... | 22 |
| 4.2.1 | Fort Halifax..... | 22 |
| 4.2.2 | Lockwood | 22 |
| 4.2.3 | Shawmut | 23 |
| 4.2.4 | Weston | 23 |
| 4.3 | RESULTS..... | 23 |
| 4.3.1 | Fort Halifax..... | 23 |
| 4.3.2 | Lockwood | 24 |
| 4.3.3 | Shawmut | 24 |
| 4.3.4 | Weston | 25 |
| 4.4 | DISCUSSION AND FUTURE PLANS | 25 |
| 4.4.1 | Fort Halifax..... | 25 |
| 4.4.2 | Lockwood | 25 |
| 4.4.3 | Shawmut | 26 |
| 4.4.3.1 | Shawmut Downstream Passage Studies | 26 |
| 4.4.4 | Weston | 26 |
| 4.4.4.1 | Weston Downstream Passage Studies | 26 |
| 5.0 | DOWNSTREAM EEL PASSAGE..... | 26 |
| 5.1 | METHODS..... | 26 |
| 5.1.1 | Fort Halifax..... | 27 |
| 5.1.2 | Lockwood | 27 |
| 5.1.3 | Shawmut | 27 |
| 5.1.3.1 | Downstream Eel Passage Effectiveness Studies at Shawmut..... | 28 |
| 5.1.4 | Weston | 28 |
| 5.1.4.1 | Downstream Eel Passage Effectiveness Studies at Weston..... | 28 |
| 5.2 | RESULTS..... | 29 |
| 5.2.1 | Fort Halifax..... | 29 |
| 5.2.2 | Lockwood | 29 |
| 5.2.3 | Shawmut | 29 |
| 5.2.3.1 | Downstream Eel Passage Studies at Shawmut | 29 |
| 5.2.4 | Weston | 29 |
| 5.2.4.1 | Downstream Eel Passage Studies at Weston | 30 |
| 5.3 | DISCUSSION AND FUTURE PLANS..... | 30 |
| 5.3.1 | Fort Halifax..... | 30 |
| 5.3.2 | Lockwood | 30 |
| 5.3.3 | Shawmut | 30 |
| 5.3.4 | Weston | 31 |

APPENDICES

Appendix A: River Flow, River Temperature, and Fish Lift Operational Status at the Lockwood Project

Appendix B: Evaluation of Silver American Eel Downstream Passage at the Shawmut Project (Kennebec River, Maine)

Appendix C: Evaluation of Silver American Eel Downstream Passage at the Weston Project (Kennebec River, Maine)

List of Tables

| | <u>PAGE</u> |
|--|-------------|
| Table 2-1. River Herring Totals at the Fort Halifax Project..... | 7 |
| Table 2-2. Non-Target Species at the Fort Halifax Project - 2008..... | 8 |
| Table 2-3. River Herring Totals at the Lockwood Project – 2008 | 10 |
| Table 2-4: Adult Atlantic Salmon Captured at the Lockwood Fish Lift, 2008..... | 13 |
| Table 2-5. Non-Target Species Totals at Lockwood Project..... | 14 |

List of Figures

| | |
|---|----|
| Figure 1. Fort Halifax Project Site Plan | 32 |
| Figure 2. Lockwood Project Site Plan..... | 33 |
| Figure 3. Lockwood Project Fish Lift | 34 |
| Figure 4A-C. Lockwood Project Downstream Fish Passage Facility Drawings | 35 |
| Figure 5. Shawmut Project Site Plan..... | 38 |
| Figure 6. Weston Project Site Plan..... | 39 |

1.0 EXECUTIVE SUMMARY

The 1998 Agreement among the members of the Kennebec Hydro Developers Group (KHDG), the Kennebec Coalition, the National Marine Fisheries Service, the State of Maine, and the U.S. Fish and Wildlife Service (“KHDG Agreement”) requires that the members of KHDG contribute \$4.75 million to the State of Maine to be used for diadromous fisheries restoration efforts in the Kennebec River basin. Approximately \$4.6 million dollars has been contributed as of December 31, 2008. KHDG members will contribute the balance in equal installments prior to January 15 of each year through the year 2010.

In accordance with the Kennebec River Restoration Fund Agreement, the National Fish and Wildlife Foundation (“NFWF”) is responsible for disbursements from the fund to the State of Maine to use for the restoration of river herring, American shad and Atlantic salmon, and for conducting American eel passage evaluations on the Kennebec River.

In addition, KHDG members have provided anadromous and catadromous fish passage and have conducted studies at the projects in accordance with the KHDG Agreement. Specific anadromous and catadromous fish passage operations, studies and restoration activities at NextEra Energy Maine Operating Services, LLC (NextEra Energy) (formerly FPL Energy Maine Operating Services, LLC) projects in 2008 are described in this report.

2.0 UPSTREAM ANADROMOUS FISH PASSAGE

2.1 METHODS

2.1.1 Fort Halifax

The Fort Halifax Project is located on the Sebasticook River in the towns of Winslow and Benton, Kennebec County, Maine. The Project powerhouse and dam are located approximately 0.3 mile above the Sebasticook River’s confluence with the Kennebec River. The powerhouse contains two horizontal-shaft Francis units rated at a total flow of approximately 1,700 cfs. A downstream fishway, one obermeyer gate, and flashboard sections provide additional flow capacity. Figure 1 shows a basic site plan and location of the Fort Halifax Project.

In accordance with the 1998 KHDG Agreement, interim fish passage consisting of a fish pump was installed at the Fort Halifax Project in the spring of 2000. Permanent upstream passage via a fish lift or partial dam breach was scheduled for 2003. In 2002, NextEra Energy proposed to partially breach the dam and surrender its FERC license in order to provide upstream fish passage. FERC subsequently approved NextEra Energy’s license surrender application in 2004. In addition, Maine Department of Environmental Protection (MDEP) issued an order approving the partial breach of the dam in 2004. Since that time, Save our Sebasticook (SOS) has challenged the various State and Federal approvals of the partial dam breach. These challenges were not successful and the original FERC and MDEP permit approvals were upheld in court. In March 2008, NextEra Energy received permits from the Town of Winslow for dam removal and the dam was subsequently removed in the summer of 2008.

The year 2008 marked the ninth and final year of upstream anadromous fish passage at the Fort Halifax Project. As described previously, the dam was removed in the summer of 2008 and migrating fish now have free passage, and fish pumping operations are no longer required. In previous years, the Maine Department of Marine Resources (MDMR) had requested that NextEra Energy capture shad at the Fort Halifax Project for use as brood stock. However, prior to the start of the 2008 migration season, MDMR informed NextEra Energy that the capture of brood stock shad from the Kennebec and Sebasticook Rivers would not be necessary in 2008 because MDMR had made arrangements to obtain all brood stock shad from the Merrimack River.

2.1.1.1 Fish Pump

The Fort Halifax Project fish pump was operated by personnel from NextEra Energy and Normandeau Associates, Inc. during the 2008 migration season.

The primary method of river herring capture involved the use of a Transvac fish pump. The pump's vacuum vessel was placed on a steel platform that was anchored to the concrete dam immediately above the turbine outflow. This location ensured attraction flow within the capture area. To facilitate capture efforts, the 10-inch-diameter vacuum intake pipe was suspended from a steel monorail allowing movement into various positions depending upon fish behavior and river flow. A 3-foot-long section of 10-inch diameter clear lexan pipe was attached to the intake end of the pipe. This made the pipe less visible to fish and increased effectiveness. A "fish-friendly" bladder-type check valve was also installed on the vacuum intake pipe. This prevented escape through the intake pipe while the pump cycled between suction and discharge phases.

During each start-up procedure, the pump was manually put through two suction-discharge cycles to insure that the pump's vessel and pipes were primed before switching the pump to automatic mode. In automatic mode, the fish pump normally completed a suction-discharge cycle in approximately 40 seconds. The mechanical control portion of the fish pump was installed in the Project's powerhouse to protect the unit from the weather. This spring, the Fort Halifax fish pump was installed during the week of May 5th. During that week, NextEra Energy contracted with a fish pump technician from Inventive Marine, Nova Scotia Canada to assist with the start-up and shake-down of the fish pump.

The pump deposited both fish and water into a square fiberglass-receiving tank located in the Fort Halifax Project's parking area. Two circular tanks were also available to hold American shad and non-target species. Oxygen was introduced into the holding tanks to reduce stress and mortality. MDMR stocking trucks could be parked alongside the holding tanks, where fish could be dip-netted from the receiving tank and counted while being placed into the stocking truck. An auxiliary water pump provided water to all holding tanks and stocking trucks, as well as cooling water for the fish-pump motor. Non-target species were documented and returned to the Project tailrace.

Approximately 3,000 fish could be held in the receiving tank. Once this number was reached, a fish-excluding device was placed over the opening to the fish-pump intake pipe allowing water to flow through the pump system while preventing the receiving tank from becoming overcrowded.

The Benton Falls and Burnham fish lifts were operational during the 2008 migration season. In the winter of 2006, MDMR asked NextEra Energy if it could fabricate and install a system that would allow MDMR to capture, sort and count alewives, and then sluice them into the Fort Halifax headpond to allow the fish to swim to Benton Falls. NextEra Energy agreed to this request and NextEra Energy and MDMR consulted on the design and implementation schedule. This new system consisted of a plastic trough inside the existing square fiberglass-receiving tank and a water sluicing system and associated piping into the headpond. River herring collected from the receiving tank could be sorted, counted and placed into the trough and then sluiced by water and gravity into the headpond.

In consultation with MDMR, NextEra Energy made modifications to the water sluicing system in early spring of 2008 to facilitate alewife counting and passage. The modifications included replacing a section of 10-inch by 8-foot sluice pipe with an 8-foot section of 36-inch plastic culvert. The culvert was cut length wise to expose a large open “trough” area where alewives were sluiced by and then counted by two biologists prior to exiting into the headpond. A small gate was installed at the outlet of the trough and could be quickly closed if undesirable species were observed. This new sluice system was utilized during the 2008 river herring migration season and proved to be very effective. This improved system eliminated the need to truck fish to up river impoundments as was done in the past.

When the 2008 anadromous fish migration season ended, NextEra Energy removed the pump vessel from the steel platform at the base of the dam. The pump was removed this season on August 9th.

2.1.2 Lockwood

The Lockwood Project (see Figure 2), is located at river mile 63 and is the first dam on the main stem of the Kennebec River. The Lockwood Project includes an 81.5-acre reservoir, an 875-foot-long and 17-foot-high dam with two spillway sections and a 160-foot-long forebay headworks section, a 450-foot-long forebay canal and two powerhouses. The dam and forebay headworks span the Kennebec River immediately upstream of the U.S. Route 201 Bridge along a site known as Ticonic Falls. The east spillway section begins at the east abutment of the dam and extends about 225 feet in a westerly direction to the small island. The west spillway extends about 650 feet from the small island in a southwesterly direction to the forebay canal headworks, which extend to the west bank of the river. Each spillway has 15-inch-high flashboards. From the headworks, the forebay canal directs water to two powerhouses located on the west bank of the Kennebec River. The original powerhouse contains six generating units and the second powerhouse contains one generating unit.

In accordance with the FERC license and the KHDG Agreement, Merimil Limited Partnership, licensee for the Lockwood Project, completed construction of a fish lift, trap, sort and transport system in the spring of 2006. The system was completed and became operational on May 5, 2006. In consultation with resource agencies, NextEra Energy developed operational and effectiveness plans for the new fish lift. These plans were filed with FERC on January 30, 2006, and approved on April 26, 2006.

2.1.2.1 Fish Lift

The entire fish lift facility is located on the westerly side of the powerhouse adjacent to Unit number 7 (see Figure 3). The sorting and trucking portion of the facility includes one 2,500 gallon 12-foot diameter round discharge tank which collects fish discharged from the 1,800 gallon fish lift hopper, two 1,250 gallon 10-foot diameter round holding tanks that sluice fish into stocking trucks and one 250 gallon rectangular holding tank for Atlantic salmon. The 2,500 gallon discharge tank is also equipped with piping that can discharge fish back into the tailrace.

The lift operates with an attraction flow of 150 cubic feet per second. Fishway entrance water velocities are 4 to 6 feet per second (fps). The lift has an approximate 10 minute cycle time and is operated as described below.

An attraction flow (150 cfs) attracts the fish through the fish lift entrance gate into the lower flume of the fish lift. The fish then swim through a vee-gate crowder and remain in the lower flume of the lift. During the cycling process, the vee-gate crowder closes to hold the fish in the hopper area. The 1,800 gallon water-filled hopper lifts the fish to the holding tank elevation and the fish are sluiced into the 2,500 gallon round discharge tank. Liquid oxygen is introduced into all tanks via carbon micro porous stones to reduce stress and mortality. Auxiliary water pumps provide a constant flow of ambient river water to all the tanks. These pumps also provide ambient river water to the stocking trucks. The fish lift operates to accommodate all target species and attraction flows are passed continuously during lift operation. The fish lift design criteria are to be able to pass 164,640 alewives, 228,470 American shad and 4,750 Atlantic salmon per year.

The Lockwood fish passage facility was operated by two NextEra Energy personnel and two seasonal employees. NextEra Energy staffed the facility as necessary to ensure that there was adequate number of personnel on site to effectively operate the facility. NextEra Energy was responsible for capturing shad, river herring and Atlantic salmon and MDMR was responsible for collecting biological data and trucking these fish to upstream spawning locations.

During the river herring and shad migration season (approximately May through mid July), the fish lift was generally manned seven days a week as necessary to meet resource agency trap and truck requirements. During the run, the lift, at times, was operated from early morning to late afternoon to capture fish effectively, to help prevent crowding, and to gather additional information on the time of day when peaks occur and the time of day when fish begin and cease migration.

During other times of the season, the fish lift was generally operated three to five times a day, seven days a week for Atlantic salmon capture. The precise timing of which was determined by NextEra Energy in consultation with the MDMR based on factors such as the number of migrating fish, water temperature, time of year and river flow.

2.1.2.2 Visual Observations

NextEra Energy personnel conducted some general visual observations of the Lockwood tailrace and spillway section for presence of fish during the upstream migration season. Observations were generally conducted one or two times a day from the fish lift holding tank platform and

from the Route 201 Bridge and lasted approximately 15 – 30 minutes. These observations were noted in the daily fishlift operations data sheet. The holding tank area is approximately 25 feet above the surface of the tailrace. The platform was the optimal area to observe fish as it allowed a clear view of the shoreline and of the tailrace area. At certain flows, the Route 201 Bridge provided a good view of the spillway section and the majority of the ledges below the spillway. Each observer was generally equipped with polarized sunglasses that reduced glare and increased overall visibility.

NextEra Energy personnel routinely monitored four underwater cameras that were hooked up to a monitor and DVD recorder. The monitor and DVD recorder were located in the control room of the fish lift and recorded generally from dawn until dusk. The cameras were also used in real time in order to aid in determining the presence of fish in the lift and maximizing fishing efforts.

Camera 1 was located just downstream of the vee-gates and provided a good view of fish moving through the vee-gates into the hopper area. Camera 2 was located just upstream of the entrance gate and provided a good view of fish swimming towards and into the fish lift. Camera 3 was located in the river just downstream of the fish lift entrance gate. This location provided a view of the tailrace area below the entrance gate. NextEra Energy also added an additional fourth camera in 2008. Camera 4 was positioned between the entrance gate and sorting tank sluice pipe on the edge of the river. This camera offered another good view of the fish lift entrance gate vicinity. Since all four cameras showed good detail, personnel could identify species and an approximate number of fish and initiate the lift cycle manually, if appropriate.

2.1.3 Shawmut

The Shawmut Project used the Lockwood fish lift and transport system as its means of interim upstream fish passage. Fish were trucked by MDMR from the Lockwood fish lift to areas of suitable habitat upstream of the project.

2.1.4 Weston

The Weston Project used the Lockwood fish lift and transport system as its means of interim upstream fish passage. Fish were trucked by MDMR from the Lockwood fish lift to areas of suitable habitat upstream of the project.

2.2 RESULTS

2.2.1 Fort Halifax

2.2.1.1 River Herring

In 2008, the fish pump captured 401,059 adult river herring at the Fort Halifax Project. Small numbers of river herring were observed the first week of May and the pump captured the first river herring on May 14th (the first day of operation). Pump operation did not begin prior to May 14th, due to high flows and some minor mechanical issues with the piping system for the fish pump. There were 10,412 river herring pumped on the first day of operation.

The peak of the river herring run occurred during the third and fourth week of May. Biologists have visually assessed the peak of the run during the previous seven seasons and have found that the peak typically occurs near the third week in May.

On May 15th the pump captured more than 36,000 river herring. There were eight additional days where over 30,000 river herring were captured and three days that the fish pump captured over 40,000 river herring.

There are several reasons why the fish pump captured large numbers of river herring this season. First of all, the flashboards were installed at the beginning of the migration period. In 2008, the flashboards were installed on May 15th one day after pump operations started and remained up throughout the entire migration season. This assisted in congregating river herring near the pump. Secondly, as a new temporary procedure, the flashboards were installed with a section of two-foot-high boards in the middle of the dam instead of the normal four-foot-high boards. This two-foot-high section was approximately 75-feet in length. In prior seasons, the entire length of the spillway was replaced with four-foot-high boards. The lower flashboards in the middle section of the dam allowed additional water to pass via this route. This decreased the amount of spill on the ledges and helped congregate river herring near the fish pump. Thirdly, NextEra Energy hired additional personnel (Normandeu Associates) for fish pump operations to net, count and sort alewives to meet MDMR capture goals. Fourthly, the newly modified sluicing system was very effective, and there was also limited MDMR truck stocking this season. This allowed more time to capture, and sluice river herring into the headpond. Finally there were large numbers of river herring available for capture and there were no commercial fishermen harvesting river herring.

MDMR have previously estimated river herring numbers returning to the Sebasticook River at 1 to 2 million fish. In 2008, the river herring numbers appeared to be consistent with previous years. May 27th marked the final day of the 13-day capture effort when the MDMR capture goal of approximately 400,000 fish was met. River herring were observed in the tailrace until mid June.

Table 2-1 lists the total amount of river herring captured per day, as well as the corresponding river flow and water temperature. Table 2-1 does not display dates where river herring were not captured, or when seasonal project shutdowns occurred due to high river flows.

The number of fish captured by the pump varied depending upon river herring density, water elevation in the tailrace, and competing areas of attraction flow. When river herring densities were lower, fewer fish were captured. Operation of at least one of the Project's two generating units produced attraction flow in the pump area. The unit outflow created several small eddies along the shoreline near the fish pump that became heavily concentrated with fish, which proved to be the most productive area for capture.

Table 2-1. River Herring Totals at the Fort Halifax Project

| Date | River Herring | Water Temp (C°) | River Flow |
|---------------|----------------------|------------------------|-------------------|
| 5/14/2008 | 10,412 | 15 | 432 |
| 5/15/2008 | 36,647 | 15.1 | 253 |
| 5/16/2008 | 40,970 | 15.5 | 259 |
| 5/17/2008 | 49,330 | 16.7 | 265 |
| 5/18/2008 | 33,020 | 16.5 | 404 |
| 5/19/2008 | 34,440 | 16.5 | 446 |
| 5/20/2008 | 29,740 | 16.5 | 360 |
| 5/21/2008 | 35,000 | 17 | 380 |
| 5/22/2008 | 29,490 | 17 | 228 |
| 5/23/2008 | 30,655 | 16.75 | 311 |
| 5/24/2008 | 29,105 | 16.5 | 333 |
| 5/25/2008 | 40,700 | 17 | 204 |
| 5/27/2008 | 1,550 | 17 | 213 |
| TOTALS | 401,059 | | |

As described above, the fish pump captured 401,059 upstream migrating river herring. The pump operated for approximately 87 hours (i.e., the total number of hours dictated by MDMR), and captured an average of 4,628 river herring per hour during the 2008 migration season. The vast majority of the captured alewives appeared to be in very good condition with minimal descaling and/or abrasions.

Out of the 401,059 river herring captured at the Fort Halifax Project during the 2008 migration season, approximately 516 mortalities were recorded. This represents a mortality rate of 0.1%. The vast majority of these mortalities occurred from fish that were not completely flushed out of the pump vessel and pump lines at the end of the day. There were also a few mortalities from fish coming in contact with the flapper valves of the pump vessel. The majority of these fish were donated to Avian Haven, a wild bird rehabilitation center in Freedom, Maine.

NextEra Energy and Normandeau personnel constantly monitored the status of the fish in the pools on the Fort Halifax ledges to avoid any stranding events. NextEra Energy has established procedures for biologists and operations personnel to follow during the herring migration. During high flows when spillage occurs over the spillway, the procedures state that water should continue to be spilled over the crest of the dam until NextEra Energy biologists are on-site and can safely remove any fish from the ledges that may be stranded when spillage stops. The procedure also requires that after flashboard replacement, the headpond be maintained at 0.5 feet below the top of the flashboards. This limits the possibility of creating spill and attracting fish onto the ledges. In addition to these procedures and visual observations, biologists maintained temporary weirs along the ledge area to limit fish access and stranding on the ledges.

NextEra Energy replaced the Fort Halifax Project flashboards on May 15, 2008. To accomplish flashboard replacement, the Project headpond was drawn below the crest of the concrete dam, eliminating any spill onto the ledge area. MDMR, Normandeau Associates, NextEra Energy biologists, and two seasonal NextEra Energy personnel were on-site for the flashboard

replacement to capture stranded fish and place them back into the river. American eel, common white sucker, smallmouth bass were the non-target species that biologists captured and safely returned to the river during flashboard replacement. During the time the flashboards were down, there were no stranding events that lead to fish kills.

2.2.1.2 American Shad

During the 2008 season, MDMR and NextEra Energy did not observe any shad in the Fort Halifax tailrace. In addition, Normandeau Associates also recorded seeing no shad in the tailrace while operating the pump this spring. No shad were captured at the Fort Halifax Project fish pump during the 2008 migration season.

2.2.1.3 Atlantic Salmon

No Atlantic salmon were observed or captured at the Fort Halifax Project fish pump during the 2008 migration season.

2.2.1.4 Non-Target Fish Species

In total, there were five different non-target species captured by the fish pump during fish restoration efforts at Fort Halifax in 2008 (see Table 2-2). Table 2-2 shows the species and the total number of non-target fish captured by the Fort Halifax fish pump.

There were no non-target fish mortalities recorded at the Fort Halifax Project during the 2008 migration season.

Table 2-2. Non-Target Species at the Fort Halifax Project - 2008

| Species | Number of Fish Captured at Pump |
|-----------------|---------------------------------|
| Sea Lamprey | 3 |
| Smallmouth bass | 10 |
| Largemouth bass | 1 |
| White Perch | 1 |
| Yellow Perch | 2 |
| TOTAL | 17 |

2.2.2 Lockwood

The fish lift was scheduled to be operational by May 1, 2008. However, due to high river flows, the official first day of lift operation was May 8, 2008. The fish lift operated properly throughout the majority of the migration season with only a couple of unscheduled shut downs. The 2007 modifications to the attraction system proved effective in 2008 as the attraction water design flow of 150 cfs was maintained throughout the majority of the migration seasons with some minor exceptions in the fall due to leaf and algae debris. The 2007 modification included moving the attraction water intake inlet higher in the water column to avoid entraining small woody debris located at the bottom of the intake canal. This modification led to very limited amounts of woody debris passing through the fish lift compared to previous years.

The Lockwood fish lift was shut down on May 20, 2008 in order to switch out the fish lift isolation screens. The four isolation screens (with 1 by 4-inch openings) located upstream of the fish lift hopper were replaced with different isolation screens (with 1 by 2 inch openings). The 1 by 4 screens were not replaced prior to the start of the 2008 migrations season because NextEra Energy wanted to start-up the fish lift with a larger mesh size in case the attraction water intake pipe was still entraining small woody debris. The larger screens would allow more river debris to pass through the fish lift to minimize potential debris issues. The 1 by 4 screens led to some alewife entrainment issues and NextEra Energy subsequently switched to the 1 by 2 screens during the remainder of the river herring and shad migration season to eliminate this issue.

Exceptionally high river flows in the Kennebec River resulted in a shutdown of fish lift operations from June 19 until June 23, 2008. The Kennebec River flow was approximately 30,000 cubic feet per second (cfs) at the Lockwood Project during that time. The fish lift was also shutdown July 1, July 25 and 26, 2008 due to high river flows. On August 20 and 21, 2008 the fish lift was down due to an issue with the fish lift hopper and discharge chute. A problem with the fish lift vee-gates resulted in a shutdown from September 23 until September 30, 2008. Each of the mechanical issues was resolved.

Generally once a week, NextEra Energy personnel shut down the attraction flow and used a pressure washer and hand rake to remove the debris from the screens. During such times, the screens were completely lifted out of the water with chain falls and cleaned allowing the debris to be flushed out of the fish lift area. Fish lift operations shutdown on August 4th until August 14, 2008, due to an annual scheduled Lockwood facility shutdown which included dewatering and debris removal from the intake canal and performing scheduled maintenance on the hydro units. At this time, the fish lift was also dewatered, inspected and cleaned.

The fish lift was scheduled to resume operations during the last two weeks in August. At that time, MDMR requested that NextEra Energy adjust the vee-gate gap from eighteen inches to approximately six inches. The original eighteen inch vee-gate gap was to allow river herring and American shad into the fish lift. However, since the herring and shad runs had ended, the vee-gate opening was narrowed with the idea of making the fish lift more of an effective trap, (i.e., if an Atlantic salmon did swim into the hopper area, the salmon would be less likely to swim out given the smaller six inch vee-gate opening.).

In total, there were 829 lifts from May 8, through October 31, 2008. October 31 marked the final day of fish lift operations for the 2008 season.

The daily river temperatures, river flows and status of the Lockwood fish lift are included in Appendix A.

2.2.2.1 River Herring

In 2008, 131,201 adult river herring were captured at the fish lift during approximately 350 fish lift cycles. This was the largest number of river herring captured since the lift became operational in 2006. To put the 2008 number into perspective, 3,500 and 3,000 river herring were captured in 2006 and 2007 respectively. The first few river herring were captured on May 8, the first day of

2008 Diadromous Fish Passage Report

operations and the last river herring were captured on July 12. The peak of the river herring run occurred from the third week in May through the beginning of June.

MDMR personnel transported 9,855 of these river herring to Wesserunsett Lake in Skowhegan, 47,944 were transported to the Shawmut Project headpond and 22,074 were transported to the upper Sebasticook drainage. In addition, there were 13,902 river herring transported out of basin by MDMR. In addition, at the request of MDMR, approximately 36,283 river herring were returned to the river below the Lockwood Project as MDMR had no other available stocking locations. The biological information for these river herring can be found in MDMR's 2008 Diadromous Fish Restoration Report.

All the river herring were caught between May 8 and July 12. Adult river herring were observed and recorded on the underwater cameras. The underwater cameras proved to be very valuable in catching the majority of the river herring. Personnel watched the river herring swim into the fish lift and therefore knew exactly when to begin a fish lift cycle. In addition, on a couple of occasions, NextEra Energy personnel observed small schools of river herring in the river just below the fish lift entrance.

The vast majority of the captured river herring appeared to be in very good condition with no apparent descaling and/or abrasions. NextEra Energy personnel recorded 1,143 mortalities out of the 131,201 adult river herring captured. The 1,143 mortalities represent a mortality rate of 0.9%. The vast majority of the mortality occurred when river herring became gilled on the 1 by 4 isolation screens before the screens were replaced by 1 by 2 isolation screens.

In total, there were 93,775 river herring trucked by MDMR personnel. On May 13, 2008, MDMR reported 1,000 river herring mortalities from an oxygen problem with one of the stocking trucks. MDMR reported an additional 24 river herring mortalities from trucking. In total, there were 1,024 river herring mortalities out of a total of 93,775 trucked river herring in spring 2008, which represents a stocking mortality rate of 1.1%.

Table 2-3 shows daily total catch rates for river herring, corresponding river temperatures and average river flows. Table 2-3 does not show dates when no herring were caught, fish lift shutdown dates, or when the flow exceeded 24,000 cfs. As per design specifications, the Lockwood fish lift shuts down when flows exceed 24,000 cfs.

Table 2-3. River Herring Totals at the Lockwood Project – 2008

| Date | River Herring Captured | River Temperature Degrees Celsius | Average River Flow Cubic Feet/Second |
|-------------|-------------------------------|--|---|
| 9-May | 598 | 10.7 | 21,550 |
| 11-May | 33 | 10.7 | 19,930 |
| 12-May | 2,968 | 10.6 | 17,400 |
| 13-May | 3,516 | 11.9 | 15,000 |
| 14-May | 4,047 | 12.6 | 12,724 |
| 15-May | 8,750 | 12 | 11,800 |
| 16-May | 19,700 | 11.8 | 8,000 |
| 17-May | 16,000 | 12 | 8,200 |
| 21-May | 5,181 | 14.4 | 5,757 |

2008 Diadromous Fish Passage Report

| Date | River Herring Captured | River Temperature Degrees Celsius | Average River Flow Cubic Feet/Second |
|--------------|-------------------------------|--|---|
| 22-May | 3,750 | 14.6 | 3,804 |
| 23-May | 12,800 | 13.3 | 5,121 |
| 24-May | 3,600 | 13.1 | 4,554 |
| 25-May | 2,500 | 13.1 | 5,624 |
| 26-May | 4,375 | 13.5 | 5,248 |
| 27-May | 5,010 | 13.4 | 5,914 |
| 28-May | 7,902 | 14 | 4,743 |
| 29-May | 3,000 | 14.5 | 4,348 |
| 30-May | 6,500 | 15.2 | 5,163 |
| 31-May | 3,600 | 15.5 | 4,267 |
| 1-Jun | 500 | 14.2 | 5,731 |
| 2-Jun | 1,684 | 15.3 | 5,361 |
| 3-Jun | 2,557 | 15.9 | 4,637 |
| 4-Jun | 6,933 | 15.8 | 5,107 |
| 5-Jun | 556 | 14.9 | 5,646 |
| 6-Jun | 19 | 15.2 | 7,316 |
| 7-Jun | 2 | 14.4 | 6,914 |
| 8-Jun | 7 | 16.3 | 6,100 |
| 9-Jun | 2,322 | 16.2 | 4,974 |
| 10-Jun | 1,760 | 17.5 | 4,534 |
| 11-Jun | 681 | 17.2 | 6,165 |
| 12-Jun | 95 | 19.3 | 17,390 |
| 13-Jun | 19 | 19.4 | 10,320 |
| 14-Jun | 25 | 19.5 | 9,467 |
| 15-Jun | 22 | 18.8 | 8,968 |
| 16-Jun | 6 | 18.4 | 8,750 |
| 17-Jun | 3 | 17.6 | 11,390 |
| 18-Jun | 6 | 16.5 | 12,445 |
| 24-Jun | 1 | 17.4 | 18,300 |
| 25-Jun | 7 | 17.6 | 16,620 |
| 26-Jun | 13 | 17.8 | 10,780 |
| 27-Jun | 21 | 19.1 | 10,226 |
| 29-Jun | 2 | 19.3 | 11,437 |
| 30-Jun | 4 | 18.6 | 14,382 |
| 2-Jul | 2 | 19.1 | 16,290 |
| 3-Jul | 1 | 21.3 | 13,840 |
| 4-Jul | 15 | 20 | 13,200 |
| 5-Jul | 5 | 20 | 10,670 |
| 6-Jul | 4 | 20.4 | 8,150 |
| 7-Jul | 3 | 21.3 | 7,680 |
| 8-Jul | 76 | 22.5 | 7,820 |
| 9-Jul | 10 | 22.9 | 7,678 |
| 10-Jul | 7 | 23.5 | 7,013 |
| 11-Jul | 2 | 23 | 5,544 |
| 12-Jul | 1 | 22.8 | 6,455 |
| TOTAL | 131,201 * | | |

* Of this total, approximately 36,283 were returned to the river below the project as MDMR had no available stocking locations for these fish.

2.2.2.2 American Shad

There were no shad captured at the fish lift during the 2008 migration season.

On June 19, 2008, the 1 by 2 inch fish isolation screens were removed and replaced by the 1 by 4 inch fish isolation screens. At that time, the river herring run was basically completed and these larger screens allowed more debris to pass through the screens without clogging them.

NextEra Energy personnel routinely monitored the four underwater cameras located in and around the fish lift for the presence of shad. NextEra Energy also conducted visual observations for the presence of shad throughout the migration season. Observations were made from the fish lift holding tank platform looking into the tailrace and from the U.S. Route 201 Bridge looking into Taconic ledges as described above.

Shad observations at the fish lift via the underwater cameras helped catch most of the shad in 2007 as NextEra Energy personnel were able to watch the shad swim into the fish lift area. Unlike 2007, no shad were observed in 2008 on any the four underwater cameras in the fish lift vicinity. The underwater camera data suggests that American Shad were not swimming in and out of the fish lift.

The tailrace fish lift platform and Route 201 bridge visual observations documented no shad during 2008. These observations also documented the presence of numerous large striped bass just downstream of the fish lift entrance. These fish were observed chasing and feeding on other fish in that location. To corroborate these observations, MDMR personnel conducting striped bass research, angled some large striped bass (38-40 inch range) just below the fish lift entrance. NextEra Energy personnel did observe some shad being angled downstream of the fish lift entrance and in various locations in the river directly below the Lockwood project. NextEra Energy and MDMR also documented some shad spawning activity in the vicinity of the Fort Halifax Park area and MDMR collected juvenile shad in a number of locations in the Kennebec River below the Project.

It is difficult to provide any one specific reason why no shad were captured at the Lockwood fish lift in 2008. Some of the reasons why no shad were captured include, but are not limited to, (1) shad were successfully utilizing historic spawning habitat below the Lockwood Project, (2) shad may not have been adequately imprinted to spawning habitat above the Lockwood Project, (3) the presence of predatory striped bass near the fish lift entrance may have had some type of behavior impact on shad passing this area, and (4) shad behavioral or fish lift hydraulic issues associated with shad entering the fish lift.

2.2.2.3 Atlantic Salmon

In 2008, 22 Atlantic salmon were captured in the fish lift. This was the largest number captured since the fish lift began operation in 2006. In 2006 and 2007, 15 and 16 fish respectively were captured. The first Atlantic salmon was captured on June 3 and the last Atlantic salmon was captured on October 1, during a total of 745 fish lift cycles. In the spring, the first Atlantic salmon was captured at a water temperature of 15.9 degrees Celsius and the last salmon was captured at 16.2 degrees Celsius. On July 10, an Atlantic salmon swam into the lift at 23.5 degrees Celsius. This was the warmest water temperature that the fish lift captured an Atlantic

2008 Diadromous Fish Passage Report

salmon. In the fall, the fish lift was operational from September 23 until October 31, 2008, but only one additional Atlantic salmon was observed and trapped during that time period. MDMR trucked the 22 Atlantic salmon to the Sandy River. The biological information and fish lift operational information regarding these Atlantic salmon is included in Table 2-4.

Table 2-4: Adult Atlantic Salmon Captured at the Lockwood Fish Lift, 2008

| Date | Age ¹ | Sex | Origin ² | River Temp (°C) ³ | River Flow (cfs) ³ |
|--|------------------|-----|---------------------|------------------------------|-------------------------------|
| 3-Jun | 2SW | F | H | 15.9 | 4,637 |
| 11-Jun | 2SW | F | W | 17.2 | 6,165 |
| 17-Jun | 2SW | M | W | 17.6 | 11,390 |
| 27-Jun | 2SW | M | H | 19.1 | 10,226 |
| 27-Jun | 2SW | F | H | 19.1 | 10,226 |
| 7-Jul | 1SW | G | H | 21.3 | 7,680 |
| 10-Jul | 2SW | F | W | 23.5 | 7,013 |
| 12-Jul | 2SW | M | H | 22.3 | 6,455 |
| 15-Jul | 1SW | G | H | 23.1 | 5,759 |
| 17-Jul | 2SW | F | W | 23.2 | 5,868 |
| 17-Jul | 2SW | M | H | 23.2 | 5,868 |
| 19-Jul | 1SW | G | H | 23.2 | 4,500 |
| 21-Jul | 2SW | F | W | 22.9 | 8,199 |
| 22-Jul | 1SW | G | H | 23.2 | 10,944 |
| 24-Jul | 2SW | M | W | 22.6 | 7,656 |
| 30-Jul | 1SW | G | H | 22.3 | 7,832 |
| 30-Jul | 3SW | F | W | 22.3 | 7,832 |
| 30-Jul | 1SW | G | H | 22.3 | 7,832 |
| 30-Jul | 2SW | U | H | 22.3 | 7,832 |
| 30-Jul | 1SW | G | H | 22.3 | 7,832 |
| 9-Sep | 2SW | M | H | 21 | 7,576 |
| 1-Oct | 2SW | M | W | 16.2 | 11,430 |
| ¹ 1SW = 1 sea-winter, 2SW = 2 sea-winters; 3SW = 3 sea-winters | | | | | |
| ² W = Wild origin, H = Hatchery origin; G =Grisle ; U = Unknown | | | | | |
| ³ River temperature and flow readings recorded before noon on all dates | | | | | |

The underwater cameras proved to be very valuable in capturing some of the Atlantic salmon. NextEra Energy watched a few of the salmon swim into the fish lift and therefore knew exactly when to begin a fish lift cycle. Atlantic salmon were caught in the early morning hours and in the afternoon. There were a couple of occasions in which an Atlantic salmon was monitored on the underwater cameras and not immediately captured. However, the fish was subsequently captured within a few minutes of the initial observation.

Most of the captured Atlantic salmon appeared to be in overall good condition. There were seven Atlantic salmon with a similar abrasion on the underside between the pectoral fins. The

abrasion area averaged in size from approximately one inch to three inches in size. It was not clear what caused the abrasions. Similar to 2006 and 2007, there were no Atlantic salmon mortalities at the fish lift during the 2008 season or during MDMR trucking efforts.

2.2.2.4 Non-Target Fish Species

There were 22 different non-target species captured at the fish lift for a total of 1,115 fish. All the non-target species were sluiced back into the river below the fish lift. There was no non-target species mortalities at the Lockwood fish lift in 2008.

NextEra Energy captured 266 yellow perch between May 8 and November 1, 2008 which was the largest non-target catch. The second highest non-target catch was smallmouth bass at 185, followed by 172 landlocked salmon.

There were two new invasive species captured in the Lockwood fish lift this 2008 season. A 38 inch post-spawned northern pike was caught and culled on June 2, 2008, and a white catfish was caught and culled on September 9, 2008.

On May 22 and 27, 2008, NextEra Energy personnel observed a shortnose sturgeon on cameras 3 and 4 which are located just below the fish lift entrance. The sturgeon was not captured or observed after that time.

Table 2-5 shows the total number of non-target species caught in the fish lift for the 2008 season.

Table 2-5. Non-Target Species Totals at Lockwood Project

| Species | Number of Fish Caught |
|---------------------|------------------------------|
| Landlocked Salmon | 172 |
| Brown Trout | 40 |
| Rainbow Trout | 7 |
| Brook Trout | 7 |
| Sea Lamprey | 13 |
| Golden Shiner | 1 |
| Common White Sucker | 79 |
| Smallmouth Bass | 185 |
| Largemouth Bass | 66 |
| Striped Bass | 39 |
| Redbreast Sunfish | 89 |
| Pumpkinseed Sunfish | 7 |
| Yellow Perch | 266 |
| American Eel | 116 |
| Black Crappie | 20 |
| Brown Bullhead | 2 |
| Fallfish | 2 |
| Northern Pike | 1 |
| White Catfish | 1 |
| Splake | 2 |
| TOTAL | 1,115 |

2.3 DISCUSSION AND FUTURE PLANS

2.3.1 Fort Halifax

2.3.1.1 Fish Pump

NextEra Energy removed the Fort Halifax dam in the summer of 2008. In 2009, migrating river herring, American shad and Atlantic salmon will have free passage to the Benton Falls fish lift eliminating the need to pump these fish at Fort Halifax.

2.3.2 Lockwood

2.3.2.1 River Herring, American Shad and Atlantic Salmon

In consultation with resource agencies, NextEra Energy will continue to follow the operation and effectiveness plans for the Lockwood fish lift during the 2009 migration season. This includes operation of the underwater cameras and daily coordination with MDMR during sorting, counting and trucking operations.

The January 30, 2006, NextEra Energy Lockwood Fish Lift Effectiveness Study Plan (Section 6.1.2) approved by FERC on April 25, 2006, indicated that upstream passage evaluations utilizing radio telemetry techniques will be conducted in the future as determined by resource agencies in consultation with NextEra Energy. The plan further states that the decision to move to radio telemetry studies will be made after no less than two full seasons of video monitoring and evaluation. NextEra Energy has completed three full seasons of video monitoring in 2006, 2007 and 2008.

In October 2008, NextEra Energy attended a fall planning meeting with the resource agencies and at that time the agencies requested that NextEra Energy undertake an upstream radio telemetry study for American shad in 2009 and a hydraulic study of fish lift attraction flows. The main reason for these studies is to attempt to explain why very limited numbers of shad have been captured at the Lockwood fish lift from 2006-2008.

2.3.2.2 Fish Lift

NextEra Energy will continue to operate the fish lift, trap, sort, and truck facility during the 2009 migration season with experience gained from the first three seasons. NextEra Energy will continue to coordinate with MDMR on a regular basis to ensure that fish lifting and sorting operations are conducted in an effective manner.

The fish lift isolation screens, maintenance gate bar rack and redesigned attraction water intake pipe installed in August 2007 will continue to be utilized during the 2009 season to help manage river debris.

NextEra Energy will hold river herring overnight to reduce the number of these fish passed downstream following capture at the fish lift. River herring will be held in two 1250 gallon tanks

(supplied with ambient river flow and oxygen as needed) until there are adequate numbers of fish to transport to upstream spawning locations.

2.3.2.3 Proposed American Shad Upstream Passage Radio Telemetry Study

The resource agencies have requested and NextEra Energy has agreed to undertake an upstream radio telemetry effectiveness study for American shad. The study will consist of monitoring a total of 25-30 adult shad.

Adult shad for the study will be captured in the river below the project via angling or some other viable method. The test fish will be placed in a tagging vessel and held immobile with fine mesh cloth. Using a canula, a radio transmitter (coded radio tags) will then be inserted through the mouth and esophagus and deposited in the stomach. After tagging, the fish will be transported and released back into the river approximately 1/2 mile downstream of the Lockwood Project.

A total of 7 stationary monitoring stations will be deployed to monitor upstream passage of tagged American shad.

Monitor Station 1 will be placed to survey fish approaching the fish lift. The receiver at Station 1 will be coupled to one 4-element Yagi antenna. The 4-element Yagi will survey the area approximately 300 feet downstream of the fish lift to detect fish approaching the fish lift.

Monitor Stations 2-3 will be located in the entrance of the fish lift and just upstream of the fish lift hopper to detect fish entering the fish lift and moving into the hopper area. The receivers at Stations 2-3 will be coupled to 12-gauge insulated copper wire dropper antennas.

Monitor Stations 4 will be located approximately 50 feet downstream of the fish lift entrance to detect fish approaching the fish lift. The receiver at Station 4 will be coupled to 12-gauge insulated copper wire dropper antennas.

Monitor Station 5 will survey fish along the lower spillway section of the dam. The receiver at Station 5 will be connected to a 4-element Yagi antenna located next to Unit 1 spillway side of the powerhouse.

Monitor Station 6 will survey fish in the upper spillway section of the dam. The receiver at Station 6 will be connected to a 4-element Yagi antenna located at the headworks structure.

Monitor Station 7 will survey fish that have moved downstream of the fish lift. The receiver at Station 7 will be connected to a 4-element Yagi antenna located in a wooded area upstream of the Donald Carter Bridge.

Additionally, manual surveys of the tailrace area down to the Donald Carter Bridge, the spillway section, and just below the fish lift will be done on generally a daily basis throughout the study period. Boat surveys will also take place periodically throughout the study period.

Further consultation will take place with the agencies to develop criteria for interpreting the results before the study is undertaken. In addition, NextEra Energy will follow the typical

consultation process where the results of the study are discussed with the resource agencies to determine what conclusions can be drawn from the studies and to come to consensus regarding the implications of the results.

2.3.2.4 Proposed Hydraulic Study of Flows in and Around the Fish Lift

NextEra Energy will undertake a hydraulic evaluation of the flows around the fish lift to determine if there are any hydraulic issues that may be negatively impacting shad attraction to the fish lift. Fish lift attraction water current velocity, continuity, and direction will be determined with a combination of a dyed water release and Acoustic Doppler Current Profiler (ADCP) velocity measurements transects during low, high and normal station operating conditions.

The dye test will use a digital recording video camera set at a location that will record the flows in the tailrace. A biodegradable FDA-approved dye solution will be discharged into the upstream fishway. The dyed water will flow out the entrance as does the normal operating jet configuration. After the initial data is gathered, it will be evaluated to see if there are any areas that should have detailed velocity studies. A series of prints of the discharge flow patterns along with all flows will be assimilated into a report. The dye test is a good visual analysis of the continuity of surface flows.

The ADCP works by emitting sound bursts and measuring the frequency change of the echo as a function of depth to determine the water velocity. The units have four 20-degree beam angle transmitters, with three used to determine a vector and location while the fourth serves as a check. The water velocity is measured in a series of equal-thickness layers called depth cells for the full depth of the water column except for a cell at the surface and a cell at the bottom interface. The equipment will be sized so the first upper cell is 0.5 meters or less and each subsequent cell will be approximately 0.25 meters. The velocity accuracy normally is +/- 0.25% of the (water + boat) velocity + or - 2.5 cm/sec. Due to potential air entrainment, the typical transect speed will be slower to develop higher accuracy. The ADCP records the velocity in three dimensions and the software has graphics that allow color-coded or vector presentations.

Depending on the results of the dyed water release, a minimum of 4 transect locations using ADCP are proposed, with three tests per location to ensure reliable data is obtained. The proposed test locations are as follows: immediately downstream of the fish lift entrance, 25 feet downstream of the fish lift entrance, 50 feet downstream of the fish lift entrance, and 75 feet downstream of the fish lift entrance. Benchmarks will be placed at location endpoints to allow repeatability of locations. Locations will be tested by floating the ADCP just under the water surface at each location from a fixed rope located on the walk platform located above and just upstream of the entrance gate. The internal flux gate compass will orient the flow and provide a bottom track. Checks on this heading will be performed with a GPS. Due to the beam angle of the unit, it will be tilted slightly to reduce side lobe interference at the immediate area of the fishway entrance. After the initial data is gathered, it will be evaluated to see if additional test locations are necessary. In addition, spot depths and elevations will be recorded along three to four transects between the entrance of the fishlift and the downstream spawning area to the Donald Carter bridge.

2.3.3 Shawmut

The Shawmut Project will use the Lockwood fish lift and transport system as its means of upstream fish passage until at least the year 2012. Permanent upstream passage at Shawmut will be operational 2 years following the earlier to occur of either of the following biological triggers:

- A. 15,000 American shad passed in any single season in the permanent passage facility at UAH-Hydro Kennebec; or
- B. A biological assessment trigger initiated for Atlantic salmon, alewife or blueback herring.

However, in no event shall permanent upstream passage be required to be operational at Shawmut before May 1, 2012.

2.3.4 Weston

The Weston Project will use the Lockwood fish lift and transport system as its means of upstream fish passage until at least the year 2014. Permanent upstream passage at Weston will be operational 2 years following the earlier to occur of either of the following biological triggers.

- A. 35,000 American shad passed in any single season in the permanent passage facility at UAH-Hydro Kennebec; or
- B. A biological assessment trigger initiated for Atlantic salmon, alewife or blueback herring.

However, in no event shall permanent upstream passage be required to be operational at Weston before May 1, 2014.

3.0 UPSTREAM EEL PASSAGE

3.1 INTRODUCTION

Pursuant to the 1998 KHDG Agreement, the MDMR, NextEra Energy and Merimil have installed upstream passage facilities (eelways) for American eel at the hydroelectric projects in the lower Kennebec River watershed and have initiated upstream eel passage studies.

3.2 METHODS

3.2.1 Fort Halifax

The eelway entrance was located at the base of the dam, in the same area that proved successful in previous years. One section of the eelway channel ran parallel to the dam, connecting to an upper turn pool. The eelway was a 20-inch-wide by 4-inch-high aluminum trough, with substrate consisting of a rigid, netted, mesh called *incamat*. The *incamat* was approximately 3/8-inches-high by 3/8-inches in diameter and covered the entire surface of the eelway. Prior to the 2007 season, NextEra Energy installed a different type of *incamat* suggested by MDMR. This *incamat* had a flat back side which laid flat against the surface of the trough. Since the *incamat* laid flatter and smoother, it prohibited eels from climbing up underneath it. The *incamat* allowed

more eels to stay on top of the substrate making the eelway more efficient. A hydraulic ram was employed to introduce water in the eelway at the exit area and to create attraction flow at the entrance. A hopper and set of rails were installed under the exit area. By using a hand winch to raise the hopper, the eels could be lifted and then counted.

3.2.2 Lockwood

The Lockwood eelway consists of a 12-inch-wide by 4-inch-high aluminum trough with substrate consisting of a rigid, netted, mesh called *incamat*. The *incamat* is approximately 3/8-inches-high by 3/8-inches in diameter and covers the entire substrate of the eelway. This *incamat* has a flat back side which lies flat against the surface of the eelway. The eelway consists of two sections connected by one turn pool. Attraction water is supplied by a battery-operated, submersible pump which supplies two spray bars located at the exit chute and at the top of the turn pool. The eelway is approximately 20-feet-long. In addition, a collection trap is located under the eelway exit area and the eels can then be counted and weighed to quantify the number migrating through the facility.

3.2.3 Shawmut

The eelway entrance was located at the most eastern end of the spillway. The eelway consists of two sections connected by one turn pool. One section of the eelway channel runs parallel to the dam and the other section runs up and over the flashboards. The eelway is a 20-inch-wide by 4-inch-high aluminum trough, with substrate consisting of a rigid, netted, mesh called *incamat*. The *incamat* is approximately 1-inch-high and covers the entire substrate of the eel passage. Attraction water is supplied by a battery-operated, submersible pump which supplies two spray bars located at the exit chute and at the turn pool. A hopper and set of rails were installed under the exit tube area. By using a hand winch to raise the hopper, the eels can be lifted and counted.

3.2.4 Weston

The eel passage facility at the Weston Project measured 24-inches-wide with 5-inch aluminum channel sides and a 1/8-inch aluminum floor. The eelway consists of two sections connected by one turn pool, with the exit attached to the top of the stanchion gate. Attraction water was supplied by a submersible electric pump and two spray bars that are located at the intersection of the exit chute and the eelway exit. A hopper and set of rails were installed under the exit chute area. By using a hand winch to raise the hopper, the eels could be lifted to the top of the abutment and counted. The exit chute tube is also hinged to allow the hopper (holding pen) to be raised to the above walkway for tending.

3.3 RESULTS

3.3.1 Fort Halifax

The flashboards were replaced on May 15 and NextEra Energy installed the eelway during the week of June 2. At that time, two foot extensions were added to the hopper rail so the eelway could be operated at lower headpond levels. NextEra Energy noted the presence of thousands of

eels while replacing the flashboards on May 15. These eels were located in the many shallow ledge pools below the dam that were connected to the river.

The eelway was operational by June 3. High river flows prevented the eelway from being installed any sooner. MDMR operated the eelway and collected and counted eels using the eelway during the migration season as they have done since the original eelway was installed in 2000. MDMR collected approximately 38,869 eels at the eelway during the 2008 migration season. MDMR shut down the eelway on August 17 due to low river flows.

3.3.2 Lockwood

Due to high river flows, the Lockwood flashboards were not installed until September 26, well after the peak and at the end of the upstream eel migration. As a result, the Lockwood eelway was not installed during the 2008 migration season.

3.3.3 Shawmut

Due to high river flows, the flashboards at Shawmut were not replaced until May 21. The eelway was installed on June 6. The eelway was generally checked on Mondays, Wednesdays, and Fridays by NextEra Energy personnel.

NextEra Energy captured a total of 322 eels at the Shawmut eelway. The captured eels were anesthetized with MS-222, then measured and weighed, and allowed to recover in fresh water. The data generated an approximate weight per eel which could then be converted into an approximate total number of eels captured. All the captured eels were then released into the headpond of the Project.

The eels had a combined total weight of 550 grams. The average eel length was 118.61 mm and the average eel weighed 1.71 grams. There were no elver mortalities at the Shawmut eelway this season.

The Shawmut eelway was severely damaged by high river flows occurring between June 20 and June 24 and remained inoperable during the remainder of the season. After the damage, MDMR was contacted by NextEra Energy regarding the damage and the ongoing new rubber dam work. Due to the eelway damage and the ongoing rubber dam work which necessitated the need to remove the eelway during the summer of 2008, MDMR indicated that NextEra Energy's Shawmut eelway activities could be suspended for the remainder of the year.

3.3.4 Weston

Due to high river flows, the Weston Project eelway was not installed until June 9. The eelway was in operation from June 9 through September 15. Based on prior successful migration seasons and adequate effectiveness study results in 2007, the Weston eelway had limited monitoring in 2008. The eelway was checked periodically during the migration season and was successfully passing migrating eels. The eelway was removed on October 9.

3.4 DISCUSSION AND FUTURE PLANS

3.4.1 Fort Halifax

NextEra Energy removed the Fort Halifax dam in the summer of 2008. In 2009, migrating eels will have free passage at Fort Halifax eliminating the need to install and operate the eelway.

3.4.2 Lockwood

The eelway will be installed and operational by June 15 or as soon as river conditions allow for safe installation and will be removed on or about September 15. NextEra Energy will conduct effectiveness studies at the Lockwood eelway in 2009. These studies will be conducted following methods used in the 2007 effectiveness studies at Shawmut and Weston. NextEra Energy will also collect and count the number of eels using the eelway.

3.4.3 Shawmut

NextEra Energy is planning to finish the installation of the rubber dam by the end of 2009. The permanent eelway will not be installed in 2009 because it will interfere with completion of the rubber dam work. NextEra Energy will periodically check the ledges during rubber dam construction and collect eels by dip netting, if necessary, based on safety considerations.

The new rubber dam will result in very limited leakage along the entire flashboard section. Flashboard leakage at a ledge outcropping at the existing eelway location is what attracts the migrating eels to the eelway. Eliminating leakage along the flashboards via the new rubber dam could change the existing eel migration location. Nighttime visual observation will occur in 2010 to observe where eels are congregating. Based on the nighttime data, NextEra Energy in consultation with resource agencies will take appropriate steps (i.e., relocate or modify existing eelway) to provide effective passage.

3.4.4 Weston

The eelway will be installed and operational from June 15 or as soon as river conditions allow for safe installation and will be removed on or about September 15.

Eels migrating up the eelway will be allowed to pass directly into the headpond. Due to the passage effectiveness of the eelway in 2007 and the collection of countable numbers of eels since monitoring began (i.e., 758 eels in 2005, 6,893 eels in 2006 and 8,361 eels in 2007) no additional monitoring or effectiveness studies are planned at Weston in 2009.

4.0 DOWNSTREAM ANADROMOUS FISH PASSAGE

4.1 INTRODUCTION

MDMR presently stocks adult alewives and juvenile shad above the Fort Halifax Project location. Therefore, as per the 1998 KHDG Agreement, NextEra Energy has been providing permanent downstream anadromous fish passage at the Fort Halifax Project.

As per the 1998 KHDG Agreement, NextEra Energy has also been providing interim measures for downstream anadromous fish passage at the Lockwood, Shawmut and Weston Projects. In 2007, the MDMR began stocking Atlantic salmon from the new Lockwood fish lift to above the Weston Project. MDMR has been stocking Atlantic salmon eggs above the Weston project since 2003. Since 2000, MDMR has been stocking adult alewives above the Shawmut project and juvenile shad above the Lockwood Project.

In 2008, NextEra Energy routinely monitored downstream passage at the Kennebec River Projects to make sure the interim passage measures were open and operating properly.

4.2 METHODS

4.2.1 Fort Halifax

NextEra Energy removed the Fort Halifax dam in the summer of 2008. In the fall of 2008, downstream migrating fish had free passage at Fort Halifax eliminating the need to provide any type of downstream passage facility.

4.2.2 Lockwood

The Lockwood Project has two surface sluices, one on the right-hand side of the intake canal just above the headworks structure and one between Units 6 and 7 on the left-hand side of the power canal. In addition to the sluices, the spillway is also used by downstream migrating fish.

The sluice above the headworks structure is a manually adjustable fixed gate. It is 7.5-foot-wide by 16-inches-deep. Flows through this sluice fluctuate with headpond elevation and range from 35 to 40 cfs and discharge over the face of the dam into a shallow pool connected to the river.

The sluice between Units 6 and 7 is a fixed gate containing five stoplogs. The sluice is 6-foot-wide by 30-inches-deep. With all stoplogs removed, this sluice passes flows in the range of 60 to 70 cfs. Flows from this sluice discharge directly into the tailrace of the Project, which is approximately 15-foot-deep.

The Lockwood Project also includes an 875-foot-long spillway section with 15-inch wood flashboards. On September 26, 2008, three orifices, 3-foot-long by 8-inches-high were placed at three locations along the spillway. The purpose of the orifices is to pass a 50 cfs minimum flow for the protection of downstream fisheries. The orifices may also provide downstream passage routes even when the project is not spilling over the top of the flashboards. The hydraulic capacity of the seven generating units at the Project is approximately 5,660 cfs.

In accordance with the interim downstream passage requirements of the 1998 KHDG Agreement, NextEra Energy uses the sluices and the spillway as a primary means of providing downstream passage for anadromous species and American eel.

On September 2, 2005, NextEra Energy filed a study plan with FERC titled "Interim Downstream Fish Passage Effectiveness Evaluation Plan". FERC approved the study plan in a

March 8, 2006 order and NextEra Energy completed the study plan during the 2007 downstream migration season. The purpose of the study was to evaluate the effectiveness of the existing interim passage measures.

4.2.3 Shawmut

The Shawmut Project has one sluice located on the right-hand side of the intake structure next to Unit 6 (see Figure 5). The sluice next to Unit 6 is a manually adjustable sluice containing three stoplogs. The sluice is 4-feet-wide by 22-inches-deep. With all stoplogs removed this sluice passes flows in the range of 30 to 35 cfs. Flows from this sluice discharge over the face of the dam and drain into a shallow pool connected to the river.

The Shawmut Project also includes a 1,100-foot-long spillway section that consists of a hinged flashboard section, a log sluice, and a four-foot high plywood flashboard section. The hydraulic capacity of the eight generating units at the Project is approximately 6,700 cfs.

In accordance with the interim downstream passage requirements of the 1998 KHDG agreement, NextEra Energy uses the sluice and spillway as a means of providing downstream passage for anadromous species and the American eel.

4.2.4 Weston

The Weston Project has one sluice located on the South Channel dam (see Figure 6). The sluice was formerly used as a log sluice and is located near the Unit 4 intake. It is 18-feet-wide by 14-feet-high and resultant flows discharge into a deep plunge pool. Maximum flow through the gate at full pond is 2,250 cfs and, during the downstream migration period, the gate is opened 1.5 feet passing 120 cfs.

The Weston Project also includes two taintor gates, an inflatable rubber dam section, and stanchion gate sections. The hydraulic capacity of the four generating units at the Project is approximately 6,000 cfs.

In accordance with the interim downstream passage requirements of the 1998 KHDG Agreement, NextEra Energy uses the log sluice and spillage as a means of providing downstream passage for anadromous species and American eel.

4.3 RESULTS

4.3.1 Fort Halifax

NextEra Energy removed the Fort Halifax dam in the summer of 2008. In 2009, downstream migrating fish will have free passage at Fort Halifax eliminating the need to provide any type of downstream passage device.

4.3.2 Lockwood

No adult alewives were observed migrating downstream through the Lockwood Project during 2008, similar to the results of previous years of observations. Reasons for the lack of post-spawn adult sightings may be attributed to: (1) subsequently low numbers of downstream migrants due to normal post-spawning mortality and attrition, and (2) the possibility that adults passed the Project during spill events or times when personnel were not at the Project. Also, the Project power canal was dewatered for maintenance from August 4 through August 14. During that time all flow was diverted over the spillway section.

Juvenile alosids were observed at the Project on a few occasions from the end of August through the end of October. Most of these fish were observed in the power canal, and limited bird or fish feeding activity was observed in the tailrace area.

In 2008, the MDMR stocked 22 Atlantic salmon from the Lockwood fish lift above the Weston Project. Additionally, some limited number of Atlantic salmon eggs had been placed in upstream stream-side incubators in prior years and would have over-wintered into 2008. NextEra Energy did not receive any reports of sightings of Atlantic salmon or salmon smolt at the Project. Reasons for the lack of post-spawn adult and smolt sightings may be attributed to: (1) the relatively low numbers stocked above the Project and the low likelihood of actually observing these low number of downstream migrants, and (2) the possibility that they passed the Project during spill events or times when personnel were not at the project.

4.3.3 Shawmut

NextEra Energy personnel observed a small number of adult alewives migrating downstream through the Shawmut Project during 2008, similar to the results of previous years of observations. Reasons for the lack of post-spawn adult sightings may be attributed to: (1) subsequently low numbers of downstream migrants due to normal post-spawning mortality and attrition, and (2) the possibility that adults passed the Project during spill events.

In the spring, the tailrace area was checked six times for the presence of fish mortalities from May 20 until June 10, 2008. During that time, NextEra Energy personnel collected 263 river herring, one black crappie, one brown trout and 2 additional juvenile salmonids. During the 2008 migration season, MDMR stocked 47,944 adult river herring into the Shawmut headpond. These fish were collected from the Lockwood fish lift and was the first time that river herring were stocked directly into the Shawmut headpond.

In 2008, the MDMR stocked 22 Atlantic salmon from the Lockwood fish lift above the Shawmut Project. Additionally, some limited number of Atlantic salmon eggs had been placed in upstream stream-side incubators in prior years and would have over-wintered into 2008. NextEra Energy did not receive any reports of sightings of Atlantic salmon or salmon smolt at the Project. Reasons for the lack of post-spawn adult and smolt sightings may be attributed to: (1) the relatively low numbers stocked above the Project and the low likelihood of actually observing these low number of downstream migrants, and (2) the possibility that they passed the Project during spill events or times when personnel were not at the Project.

4.3.4 Weston

In 2008, the MDMR stocked 22 Atlantic salmon from the Lockwood fish lift above the Weston Project. Additionally, some limited number of Atlantic salmon eggs had been placed in upstream stream-side incubators in prior years and would have over-wintered into 2008. NextEra Energy did not receive any reports of sightings of Atlantic salmon or salmon smolt at the Project. Reasons for the lack of post-spawn adult and smolt sightings may be attributed to: (1) the relatively low numbers stocked above the Project and the low likelihood of actually observing downstream migrants, and (2) the possibility that they passed the Project during spill events.

4.4 DISCUSSION AND FUTURE PLANS

4.4.1 Fort Halifax

NextEra Energy removed the Fort Halifax dam in the summer of 2008. In 2009, downstream migrating fish will have free passage at Fort Halifax eliminating the need to provide any type of downstream passage device.

4.4.2 Lockwood

Based on consultation during 2008 and 2009 with resource agencies, NextEra Energy is planning to install a downstream passage facility. This facility will consist of a 10-foot-deep floating boom leading to a new surface sluice gate (see Figure 4A-C). The facility was originally scheduled to be installed in the spring of 2009, however logistical delays have moved the installation date to the summer of 2009. This facility is intended to provide safe downstream passage for Atlantic salmon smolt, Atlantic salmon kelts, adult and juvenile alewife, and adult and juvenile American shad. The resource agencies have requested that NextEra Energy operate the new downstream passage facility at Lockwood from April 1- December 30 annually. Due to the absence of any specific Atlantic salmon smolt and kelt migration period data for the Kennebec drainage, it is difficult to say that April 1 - December 31 is the actual migration period. NextEra Energy proposes that in consultation/cooperation with MDMR, it will gather specific data on smolt and kelt migration timing in the Kennebec drainage to better quantify the migration period. NextEra Energy will also put together time series information on April, May and June Kennebec River flows at Lockwood in an attempt to answer some questions on spillage volumes and resultant smolt passage. In addition, during the 2009 guidance device shake down period, NextEra Energy will evaluate the logistical issues surrounding installation and operation during the migration period and removal prior to winter ice-in conditions.

NextEra Energy will use the 2009 migration season as a shake-down period for the new facility and will evaluate its resistance to tearing, debris loading and other mechanical issues. NextEra Energy will also attempt to gather some general qualitative observations of fish passage at the facility as feasible. In 2010, NextEra Energy in consultation with resource agencies will conduct a pit tagging or other type of quantitative study to evaluate the effectiveness of the facility for the target fish species.

4.4.3 Shawmut

NextEra Energy will operate interim downstream passage measures at Shawmut for Atlantic salmon smolt, Atlantic salmon kelts, and adult and juvenile alewife from April 1 - December 30 annually as river conditions allow.

4.4.3.1 Shawmut Downstream Passage Studies

NextEra Energy will consult annually with the resource agencies on the need to initiate downstream passage studies for adult river herring, adult American shad, adult Atlantic salmon and salmon smolt.

NextEra Energy anticipates that the adult shad and river herring studies will begin when adult shad and additional numbers of river herring are stocked above the Shawmut dam and after further consultation with the MDMR, NMFS and USFWS.

NextEra Energy will consult with resource agencies and develop draft study plans (for agency review and comment) to assess downstream passage for smolts and kelts at Shawmut by September 30, 2009.

4.4.4 Weston

NextEra Energy will operate interim downstream passage at Weston for Atlantic salmon smolt and Atlantic salmon kelts from April 1-June 15 and November 1-December 30 annually as river conditions allow.

4.4.4.1 Weston Downstream Passage Studies

NextEra Energy will consult annually with the resource agencies on the need to initiate downstream passage studies for adult river herring, adult American shad, adult Atlantic salmon and salmon smolt.

NextEra Energy anticipates that the adult shad and river herring studies will begin when adult shad and additional numbers of river herring are stocked above the Weston dam and after further consultation with the MDMR, NMFS and USFWS.

NextEra Energy will consult with resource agencies and develop draft study plans (for agency review and comment) to assess downstream passage for smolts and kelts at Weston by September 30, 2009.

5.0 DOWNSTREAM EEL PASSAGE

5.1 METHODS

At Lockwood, the 2007 radio telemetry studies demonstrated effective downstream eel passage via the deep canal gate adjacent to Unit 1. This gate was opened during the 2008 downstream eel migration period. Surface sluice gates are opened seasonally at Fort Halifax, Shawmut and

Weston to provide interim downstream passage for clupeids and various Atlantic salmon life stages as applicable. These same gates provide interim downstream passage for eels. In addition, unregulated spillage over flashboards and turbine passage are routes that migrating eels may use.

In 2004, NextEra Energy began a program of systematic searches for dead fish or injured eels in the tailrace of each project. The program started by conducting periodic checks of the tailraces during the 2004 fall migration season with observations done by wading in certain areas of the tailraces. Information from these sampling episodes helped to identify areas where dead fish or injured eels collected (or may likely collect) in each of the tailraces and focused efforts and sampling techniques in 2005, 2006 and 2007. In 2008, observations were conducted in the morning generally on a daily basis from early September until late October at Lockwood and Shawmut and generally about two times per week at Weston.

5.1.1 Fort Halifax

The Fort Halifax dam was removed in the summer of 2008. No tailrace observations were conducted in the fall of 2008.

5.1.2 Lockwood

The Lockwood wading observations were conducted generally daily along the west shoreline below the fish lift for approximately 200-300 yards.

In addition, NextEra Energy used a canoe, as well as an underwater camera and view tubes to access and observe areas that could not otherwise be accessed by wading. At Lockwood, these areas included the Unit 1- 6 tailrace area, Ticonic Bay and both sides of the Kennebec River down below the mouth of the Sebasticook River. NextEra Energy personnel checked all possible areas in the Lockwood tailrace that were safe to wade or canoe on various occasions.

On various occasions, NextEra Energy personnel would use binoculars from specific vantage points to view inaccessible tailrace areas at the projects. At Lockwood, these vantage points included the second floor windows at the Lockwood powerhouse.

5.1.3 Shawmut

The Shawmut wading observations were conducted along the west shoreline below Units 7 and 8 tailrace areas for approximately 200-300 yards.

In addition, NextEra Energy used a canoe, as well as an underwater camera and view tubes to access and observe areas that could not otherwise be accessed by wading. At Shawmut, these areas included the Units 7 and 8 discharge canal and tailrace area below the canal, and an area below the Units 1-6 tailrace.

Also on various occasions, both sides of the Shawmut tailrace were checked down to the first set of power lines that cross the river, approximately $\frac{3}{4}$ of a mile below the Project. At this location, there are two small shallow island areas that were checked during the migration season. That

section of river beyond the power lines is relatively deep which is unsafe to wade, even during low river flows.

At times of low river flows, NextEra Energy personnel were able to wade from Unit 7 and 8 discharge canal, downstream to the two islands and down to the power lines that cross the river. NextEra Energy personnel checked all possible areas in the Shawmut tailrace that were safe to wade or canoe on numerous occasions and under changing river flows.

On various occasions, NextEra Energy used binoculars from specific vantage points to view inaccessible tailrace areas at the projects. At Shawmut, these vantage points included the Units 1-6 powerhouse roof.

5.1.3.1 Downstream Eel Passage Effectiveness Studies at Shawmut

The 2007 downstream eel radio telemetry study at Shawmut indicated that an additional year of testing should be conducted in the fall of 2008 while utilizing primarily Units 1 – 6 for nighttime generation (and restricting the nighttime use of Units 7 and 8) to consider the effect of the rack spacing or various operation options that may improve eel passage at the Shawmut Project.

NextEra Energy contracted Normandeau Associates to conduct additional downstream eel passage effectiveness studies at the Shawmut Project in 2008 using radio telemetry techniques. These studies are specifically described in a report in Appendix B.

5.1.4 Weston

The Weston wading observations were conducted along the west shoreline below the south channel dam for approximately 200 yards.

On one occasion, NextEra Energy personnel conducted a river observation in an area known as the Big Eddy which is located approximately $\frac{3}{4}$ of a mile below the Project. This area was checked on October 9th. There were no observations conducted further below this area as that stretch of river becomes much deeper making wading impractical.

Also, NextEra Energy on various occasions used binoculars from specific vantage points to view inaccessible tailrace areas at the projects. At Weston, these vantage points included the foot bridge just below the South Channel dam and at the South Channel Dam.

5.1.4.1 Downstream Eel Passage Effectiveness Studies at Weston

NextEra Energy contracted Normandeau Associates to conduct downstream eel passage effectiveness studies at the Weston project in 2008 using radio telemetry techniques. These studies are specifically described in a report in Appendix C.

5.2 RESULTS

5.2.1 Fort Halifax

The Fort Halifax dam was removed in the summer of 2008. No tailrace observations were conducted in the fall of 2008.

5.2.2 Lockwood

NextEra Energy personnel found no eel mortalities below the Lockwood project during the downstream migration season.

A single eel mortality was found on the Lockwood canal trash racks during the 2008 downstream migration season. This eel was found while NextEra Energy personnel operated the trash rake on October 7, 2008.

5.2.3 Shawmut

NextEra Energy personnel collected only three eel mortalities below the Shawmut project in 2008.

5.2.3.1 Downstream Eel Passage Studies at Shawmut

The specific results of these studies are included in Appendix B of this report. In summary,

- With the deep gate set at 1.5 feet (passing approximately 270 cfs) and Units 1-6 on and Units 7 and 8 off at night, approximately 58.3% (7 of 12) of the silver American eel that passed via Shawmut's forebay utilized the deep gate.
- With the deep gate set at 2.5 feet (passing approximately 425 cfs) and Units 1-6 on and Units 7 and 8 off at night approximately 83.3% (25 of 30) of the silver American eel that passed via Shawmut's forebay utilized the deep gate.
- Immediate survival of silver American eel passing through the deep gate set at 425 cfs was 92.0% (23 of 25). Immediate survival through the deep gate when set at 270 cfs was 57% (4 of 7).
- Immediate survival of silver American eel passing through Units 1-6 was 90% (9 of 10).
- The deep gate set at 2.5 feet in combination with shutting off Units 7 and 8 at night provides effective passage for eels at the Shawmut Project.

5.2.4 Weston

NextEra Energy personnel found no eel mortalities below the Weston project in 2008.

5.2.4.1 Downstream Eel Passage Studies at Weston

The specific results of these studies are included in Appendix C of this report. In summary,

- 29.0% (7 of 24) test eels used the obermeyer gates, 13.0% (3 of 24) used the taintor gate, 58.3% (14 of 24) used the turbines and none used the South Channel log sluice.
- Obermeyer gate immediate survival was 85.7% (6 of 7) and taintor gate immediate survival was 100% (3 of 3) for test eels.
- Turbine Unit 2 immediate survival was 83.3% (5 of 6), turbine Unit 3 immediate survival was 100% (2 of 2), and turbine Unit 4 immediate survival was 83.3% (5 of 6) for test eels.
- 85.7% (12 of 14) of the test eels that passed through the Weston turbines were detected alive 10 miles downstream at the Shawmut project.
- 75% (9 of 12) Weston test eels detected alive at Shawmut subsequently passed Shawmut (6 via the deep gate, two via the spillway and one via Unit 5) and 100% (9 of 9) were detected alive 5 miles downstream in the Hydro Kennebec headpond.

5.3 DISCUSSION AND FUTURE PLANS

5.3.1 Fort Halifax

The Fort Halifax dam was removed in the summer of 2008 so downstream migrating eels have free passage at the Project so no studies or additional work is necessary.

5.3.2 Lockwood

NextEra Energy will continue to use the deep sluice next to Unit 1 as the primary permanent downstream passage measure for out-migrating adult American eels. Licensee proposes to open the deep gate 8 hours a night during a six-week period between September 15 and November 15 inclusive. The gate will be set at approximately 1.5 feet passing approximately 300 cfs to provide effective passage.

5.3.3 Shawmut

Based the 2008 studies, Licensee proposes to use the deep gate located between the two powerhouses as the primary downstream passage measure for out-migrating adult American eels. Licensee proposes to open the deep gate and turn off Units 7 and 8 at night, for 8 hours a night, during a six-week period between September 15 and November 15 inclusive. The gate will be set at approximately 2.5 feet passing approximately 425 cfs to provide effective passage. Licensee reserves the right to modify the above proposal in the future if other downstream eel passage measures are identified in consultation with resource agencies. In addition, to resolve the deep gate mortality issue, NextEra Energy in consultation with resource agencies will design and construct in 2009 a plunge pool below the outlet of the deep gate.

5.3.4 Weston

Based on 2008 studies, the taintor gate, the obermeyer gates and the log sluice don't appear to be the preferred passage routes for eels. In addition, the Weston Station does not have an existing deep gate for eel passage like the Shawmut and Lockwood projects, and installation of a new deep gate would be difficult due to the stations "in river" location. Based on the above site constraints and based on the immediate turbine survival rates of 85.7%, NextEra Energy will initiate further consultation with the resource agencies in the summer of 2009 to evaluate downstream eel passage options for the project.

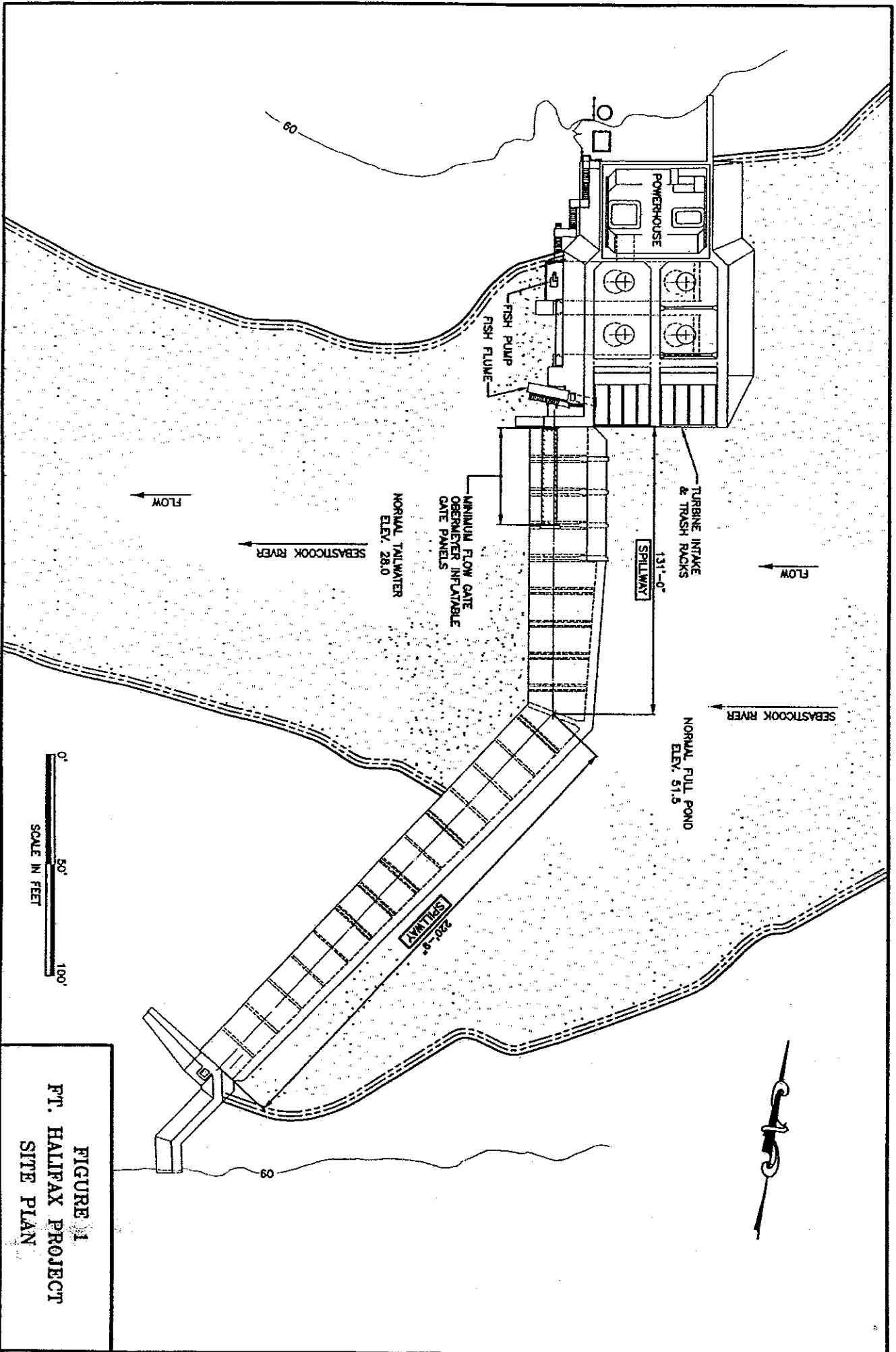

FIGURE 1
FT. HALIFAX PROJECT
SITE PLAN

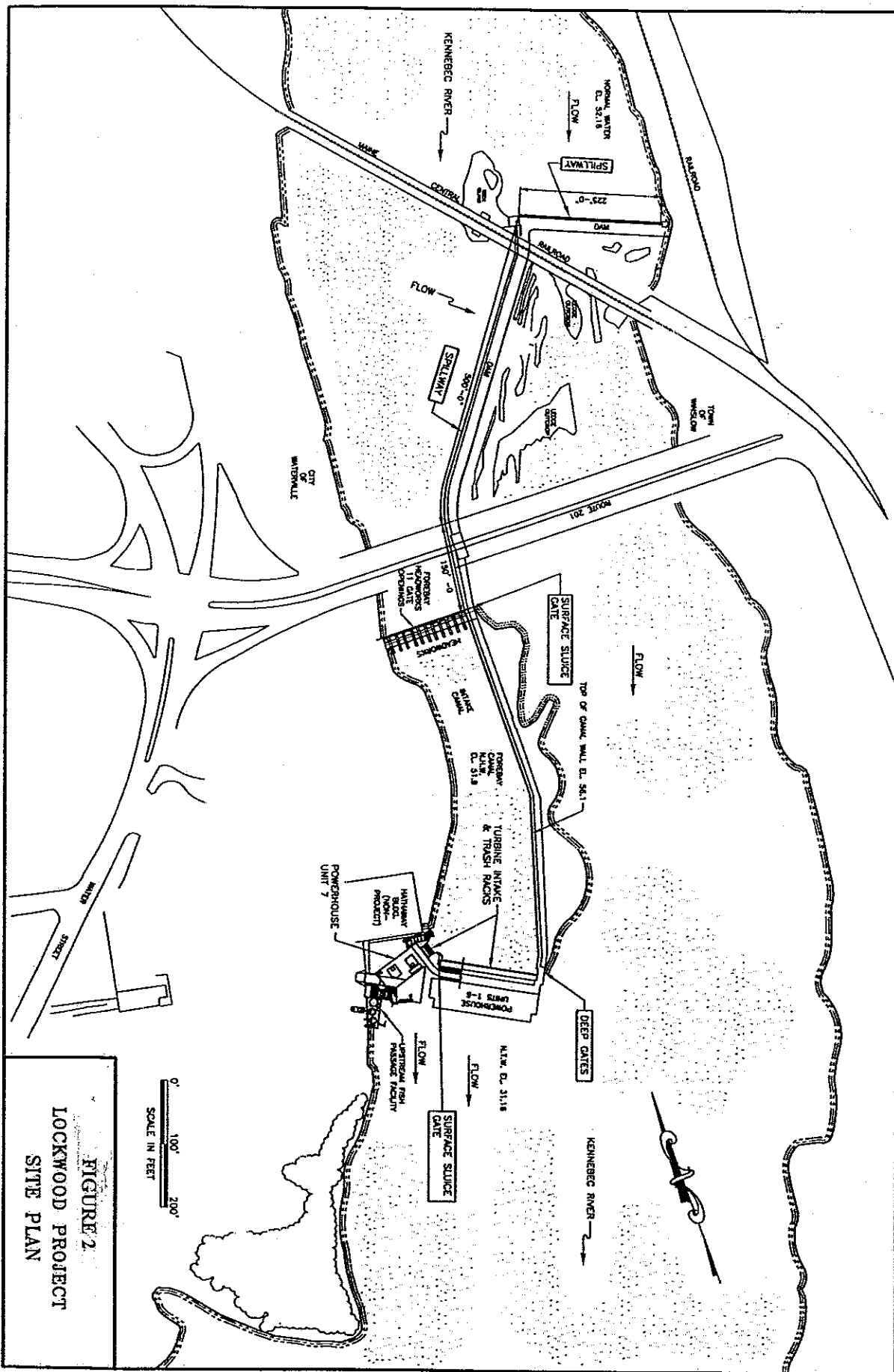
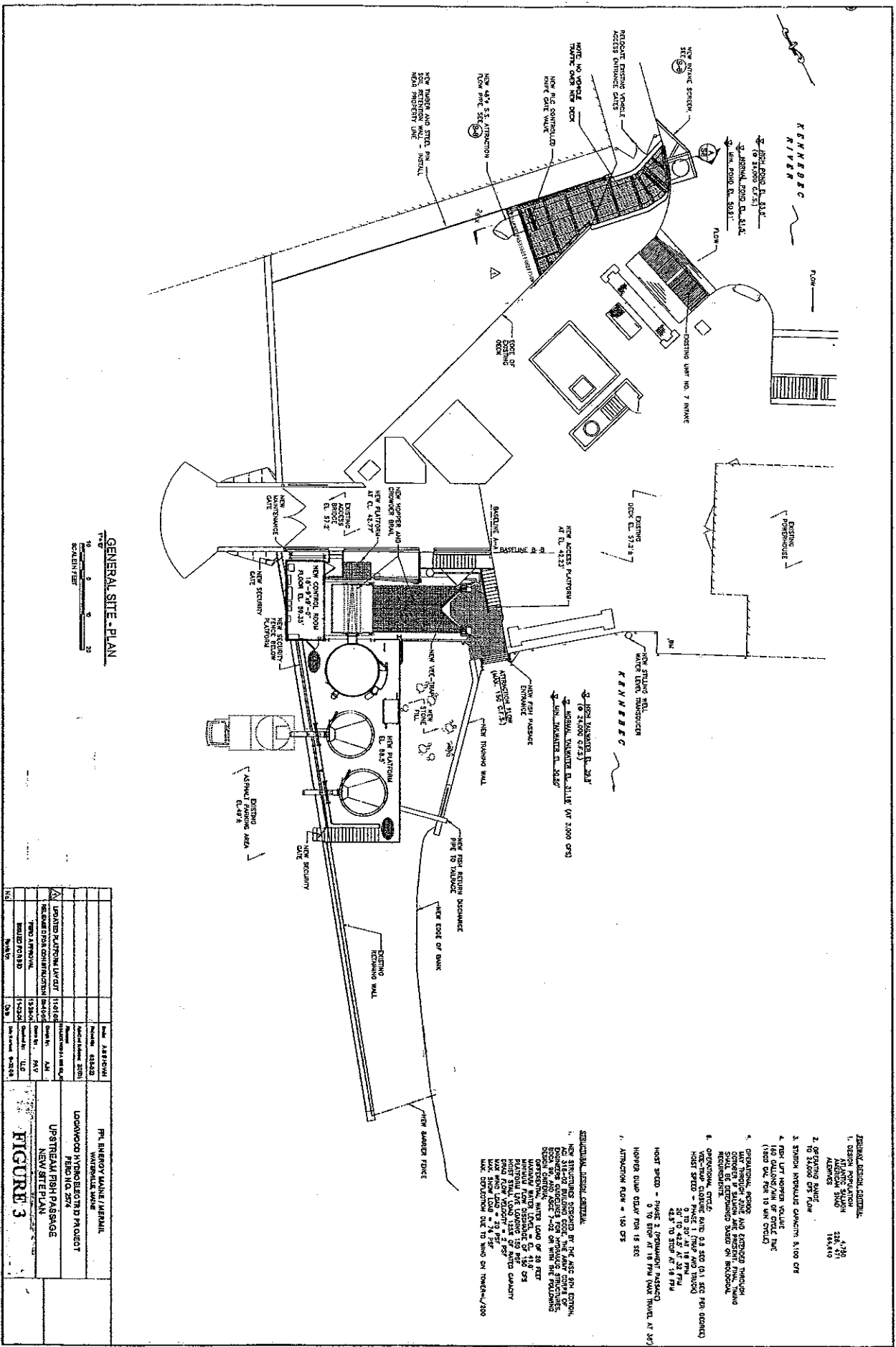

FIGURE 2
LOCKWOOD PROJECT
SITE PLAN

0 100' 200'
 SCALE IN FEET



GENERAL SITE PLAN

0 10 20
FOOT
SCALE: 1/8" = 1'-0"

- ESTIMATED INITIAL CAPITAL:**
- NEW STRUCTURES DESIGNED BY THE ASS. OF CORR. AND 314-57 MILLION COST. THE MAIN COVER OF EACH POND AND ACCESS TO 2.02 ON WHICH THE FOLLOWING DECKS, CONCRETE WALKS, AND STAIRS WOULD BE PLACED.
 - MANUAL WATER LEVELS AT 11.0 CFS PLANTING ARE LOCATED 150 FEET FROM THE PLANTING AREA TO EACH END OF THE CANALS.
 - NEW FISH PASSAGE AND STYLING WALL DEVELOPMENT COST TO BE DETERMINED BY THE STATE OF TEXAS.
- NET COST - Phase 1 (Development)**
NET COST - Phase 2 (Operation)
NET COST - Phase 3 (Operation)
HOPPER DUMP QUANT FOR 18 SEC
ATTORNEY FEE = 150.00

GENERAL DESIGN DATA:

- DESIGN POPULATION: 228,751
- DESIGN YEAR: 1974
- DESIGN FLOW: 150.00 CFS
- DESIGN WIND VELOCITY: 40.00 MPH

| PREPARED BY | | DATE | | DRAWN BY | | CHECKED BY | | APPROVED BY | |
|-----------------|----------|-------------|----------|-------------|----------|-------------|----------|-------------|----------|
| ASST. ENGR. | 11/11/74 | ASST. ENGR. | 11/11/74 | ASST. ENGR. | 11/11/74 | ASST. ENGR. | 11/11/74 | ASST. ENGR. | 11/11/74 |
| ENGR. | 11/11/74 | ENGR. | 11/11/74 | ENGR. | 11/11/74 | ENGR. | 11/11/74 | ENGR. | 11/11/74 |
| FIGURE 3 | | | | | | | | | |

- GENERAL NOTES:
- DESIGN SPECIES
ATLANTIC SALMON
AMERICAN SHAD
RIVER HERRING
EELS
 - FLOWS
- TOTAL #1- #6 POWERHOUSE UNITS FLOW UP TO 3,960 CFS
- NEW POWERHOUSE FLOW UP TO 1,700 CFS
- DOWNSTREAM FISHWAY FLOW UP TO 340 CFS
 - DRAINAGE AREA ? SQUARE MILES
 - FLASHBOARDS
 - SPILLWAY ? UNCONTROLLED
 - PERIODS OF OPERATION ?
DOWNSTREAM

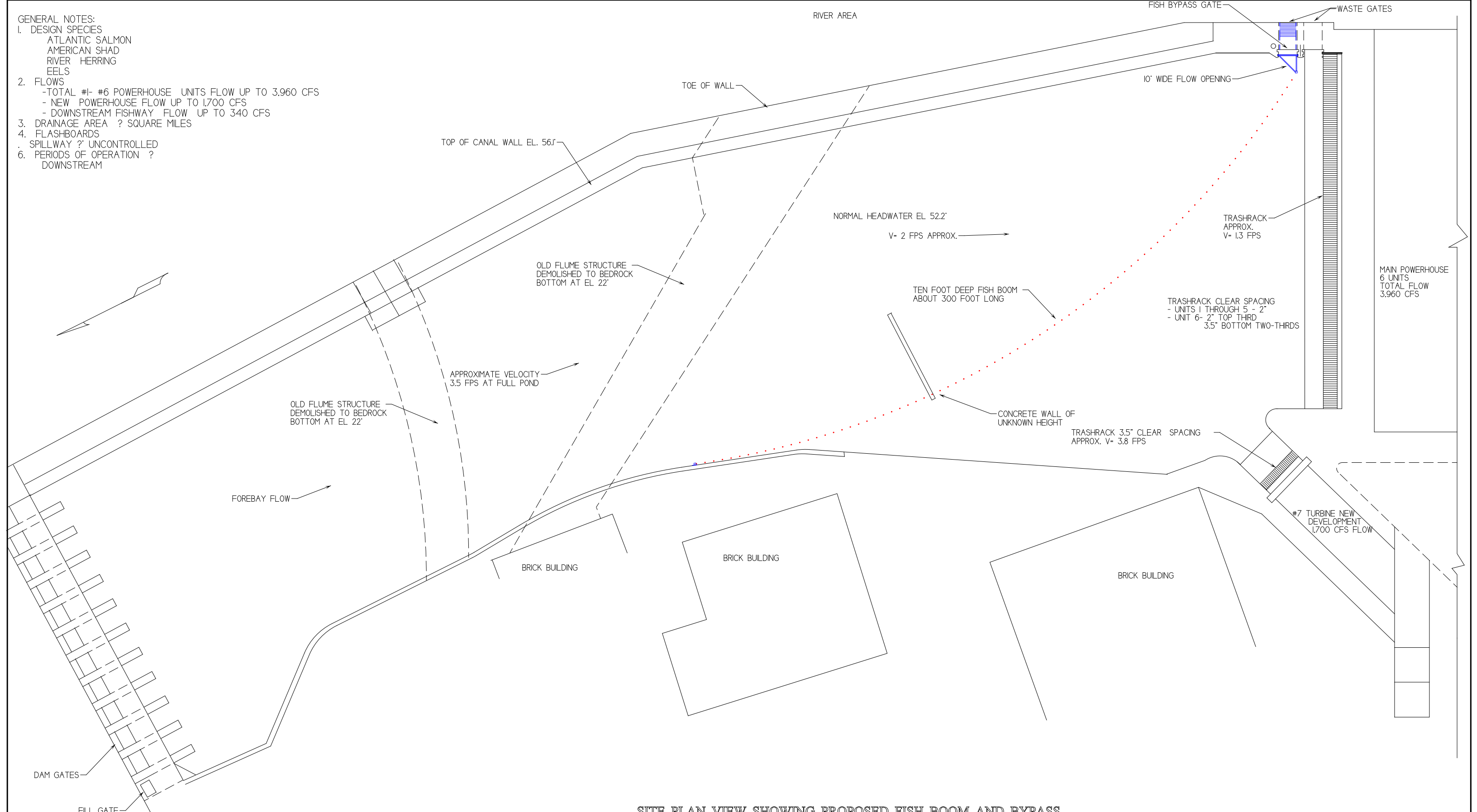

SITE PLAN VIEW SHOWING PROPOSED FISH BOOM AND BYPASS

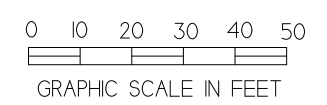

| | | |
|--------------|----------|-------------------------|
| 1-16-09 | JT | ADDRESS AGENCY COMMENTS |
| 11-25-08 | JT | ISSUED FOR COMMENT |
| Date | Chkd. | Revision |
| Designed by: | | Date: |
| Scale: | AS NOTED | |

Figure 4A

**LOCKWOOD HYDROELECTRIC PROJECT
MERIMIL LIMITED PARTNERSHIP
FERC NO. 2574-15**

DOWNSTREAM FISH PASSAGE
BOOM/BYPASS

GENERAL SITE PLAN LOCATING BOOM

LAKESIDE ENGINEERING, INC.
MIRROR LAKE, NH

SHEET 1 OF 3

- GENERAL NOTES:
 1. APPROXIMATELY 2,000 SF UNDER BOOM
 2. APPROXIMATE BOOM AREA
 1,200 SF SOLID AND 1,800 SF NETTING
 3. MAX TURBINE FLOW 5,660 CFS

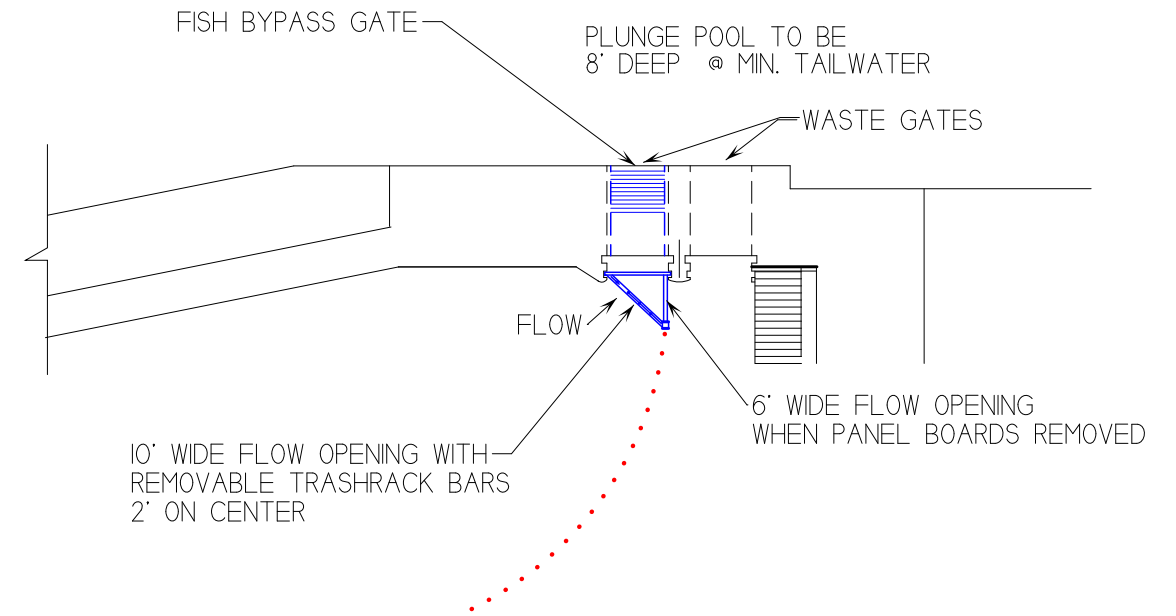

PLAN VIEW EXISTING WASTE GATES

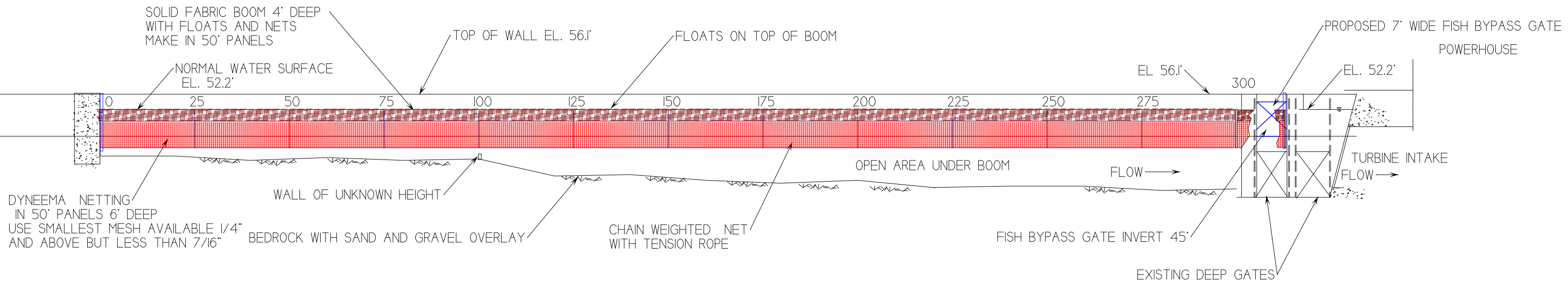

ELEVATION HYBRID FISH BOOM WITH NET AND MEMBRANE

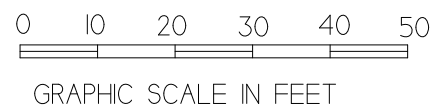

Figure 4B

**LOCKWOOD HYDROELECTRIC PROJECT
 MERIMIL LIMITED PARTNERSHIP
 FERC NO. 2574-15**

DOWNSTREAM FISH PASSAGE
 BOOM/BYPASS
 HYBRID BOOM ELEVATION- NET/MEMBRANE

| | | |
|--------------|----------|-------------------------|
| 1-16-09 | JT | ADDRESS AGENCY COMMENTS |
| 11-25-08 | JT | ISSUED FOR COMMENTS |
| Date | Chkd. | Revision |
| Designed by: | | Date: |
| Scale: | AS NOTED | |

LAKESIDE ENGINEERING, INC.
 MIRROR LAKE, NH

SHEET 2 OF 3

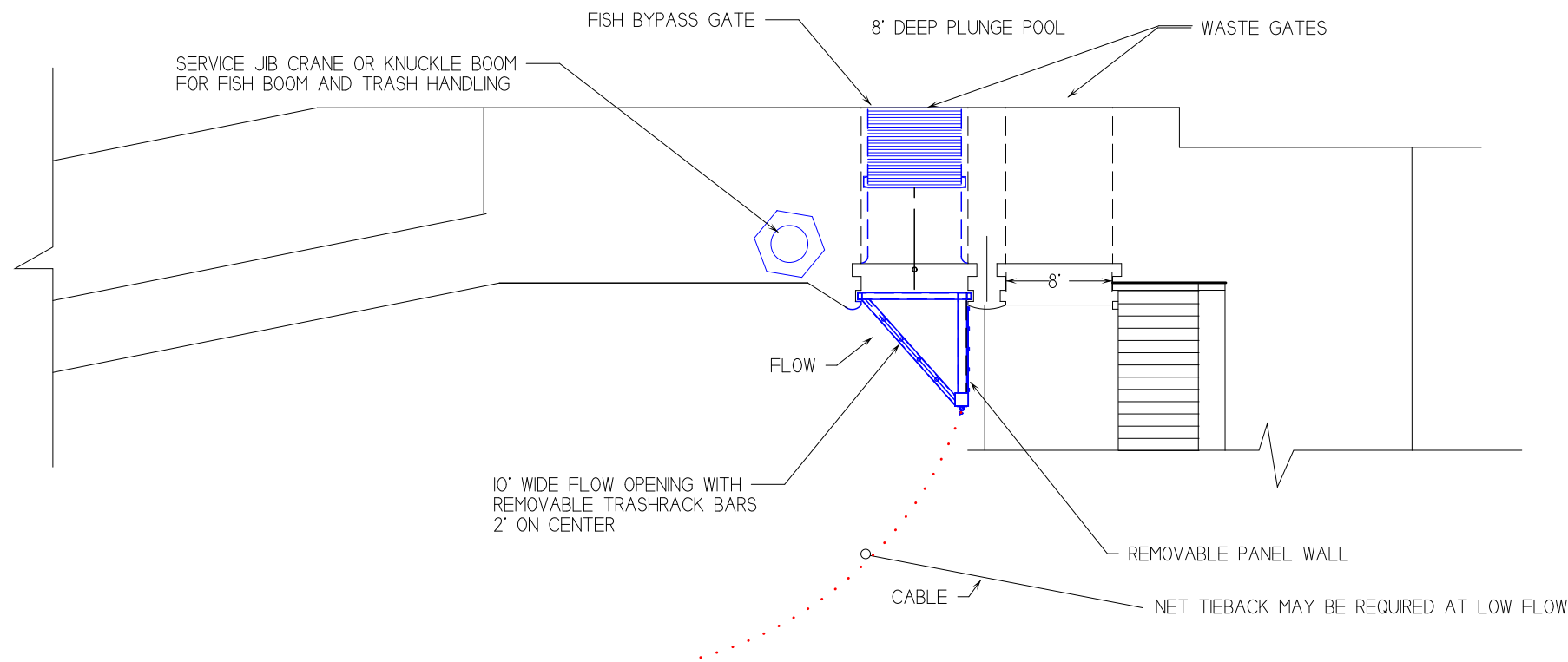

PLAN VIEW BYPASS GATE MODIFICATIONS

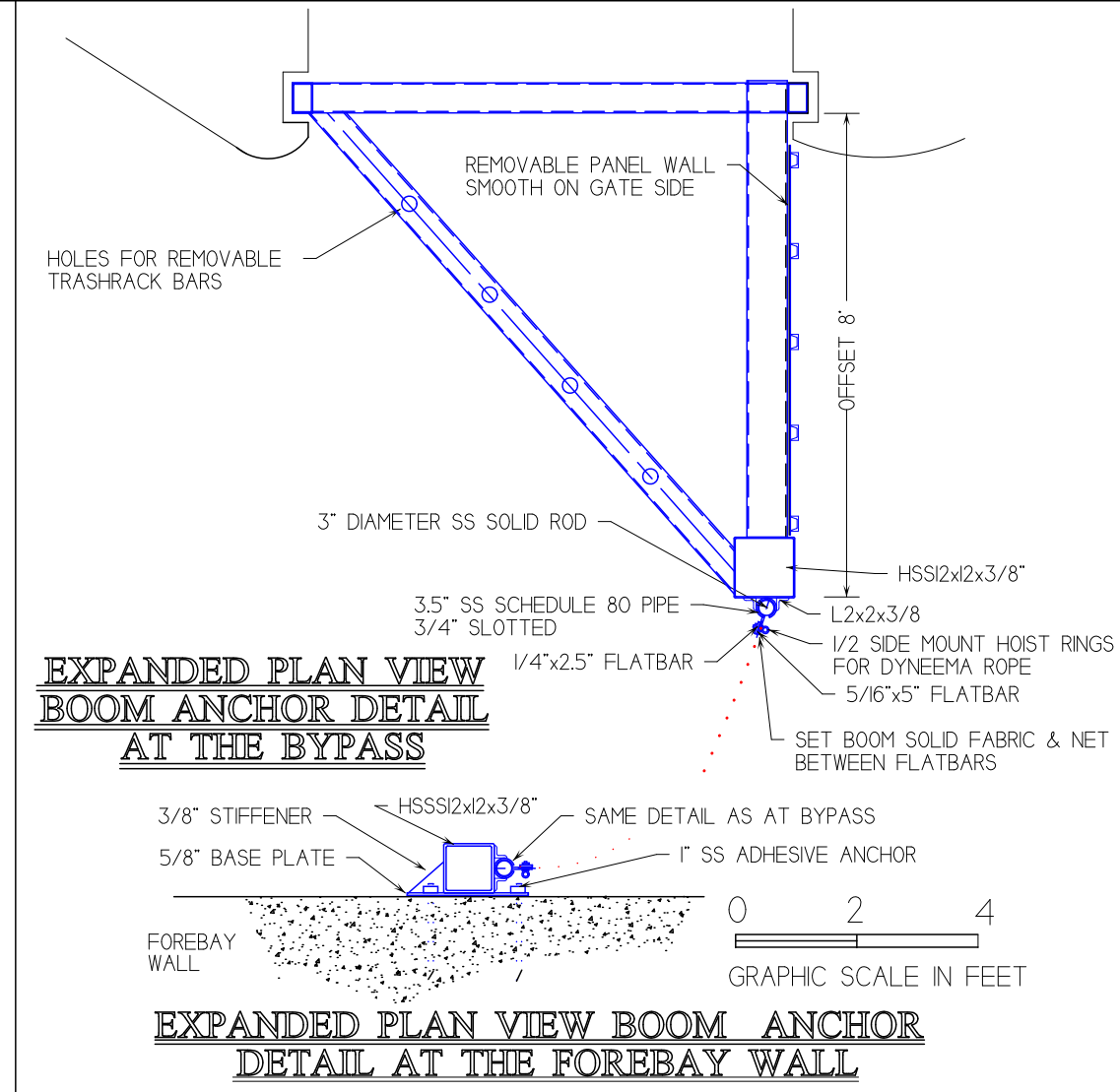

EXPANDED PLAN VIEW BOOM ANCHOR DETAIL AT THE BYPASS

EXPANDED PLAN VIEW BOOM ANCHOR DETAIL AT THE FOREBAY WALL

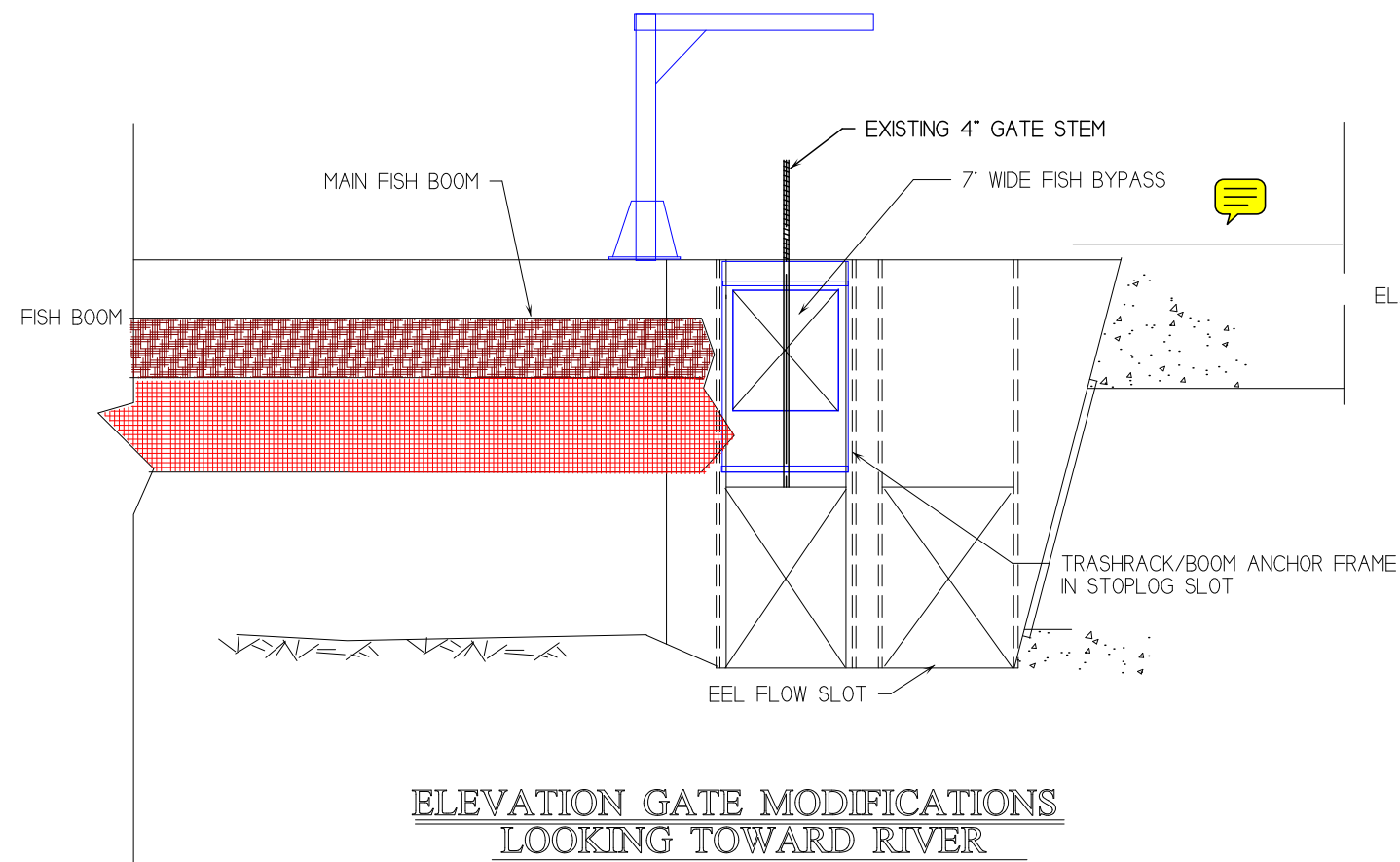

ELEVATION GATE MODIFICATIONS LOOKING TOWARD RIVER

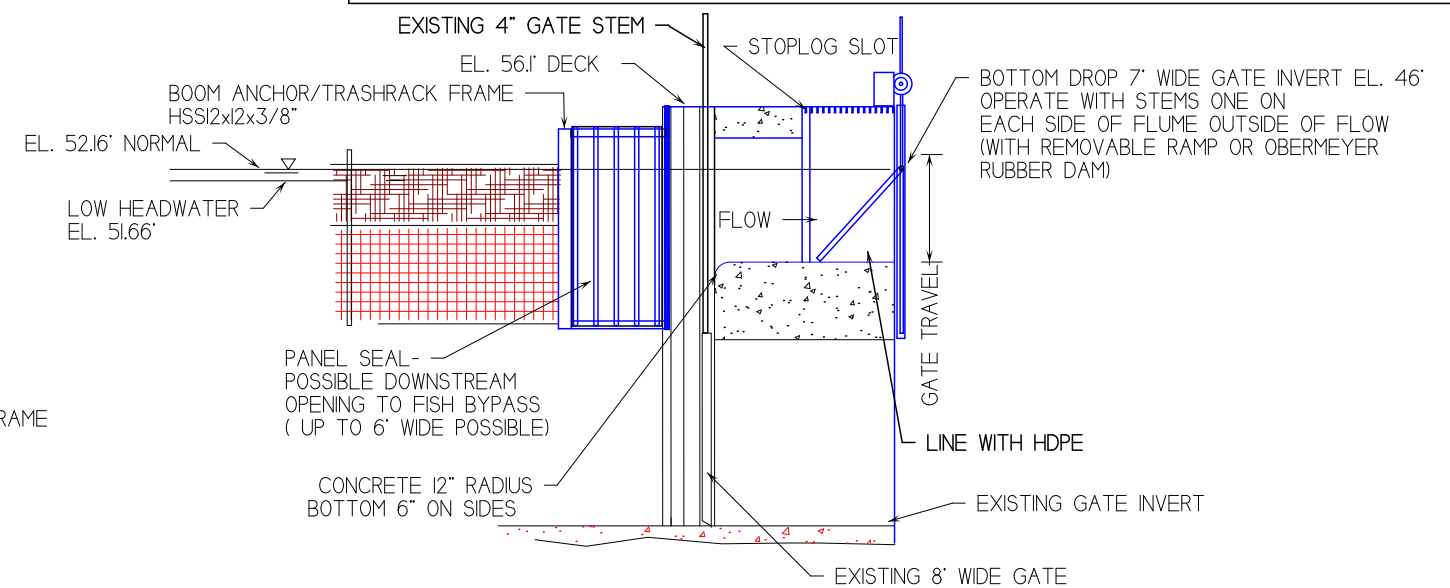

SECTION THROUGH BYPASS MODIFIED GATE



| Date | Chkd. | Revision |
|----------|-------|-------------------------|
| 1-16-09 | JT | ADDRESS AGENCY COMMENTS |
| 11-25-08 | JT | ISSUED FOR COMMENT |
| | | |
| | | |

Designed by: _____ Date: _____
Scale: AS NOTED

Figure 4C

**LOCKWOOD HYDROELECTRIC PROJECT
MERIMIL LIMITED PARTNERSHIP
FERC NO. 2574-15**

DOWNSTREAM FISH PASSAGE
BOOM/BYPASS

BYPASS GATE ALTERNATIVE DETAILS

LAKESIDE ENGINEERING, INC.
MIRROR LAKE, NH

SHEET 3 OF 3

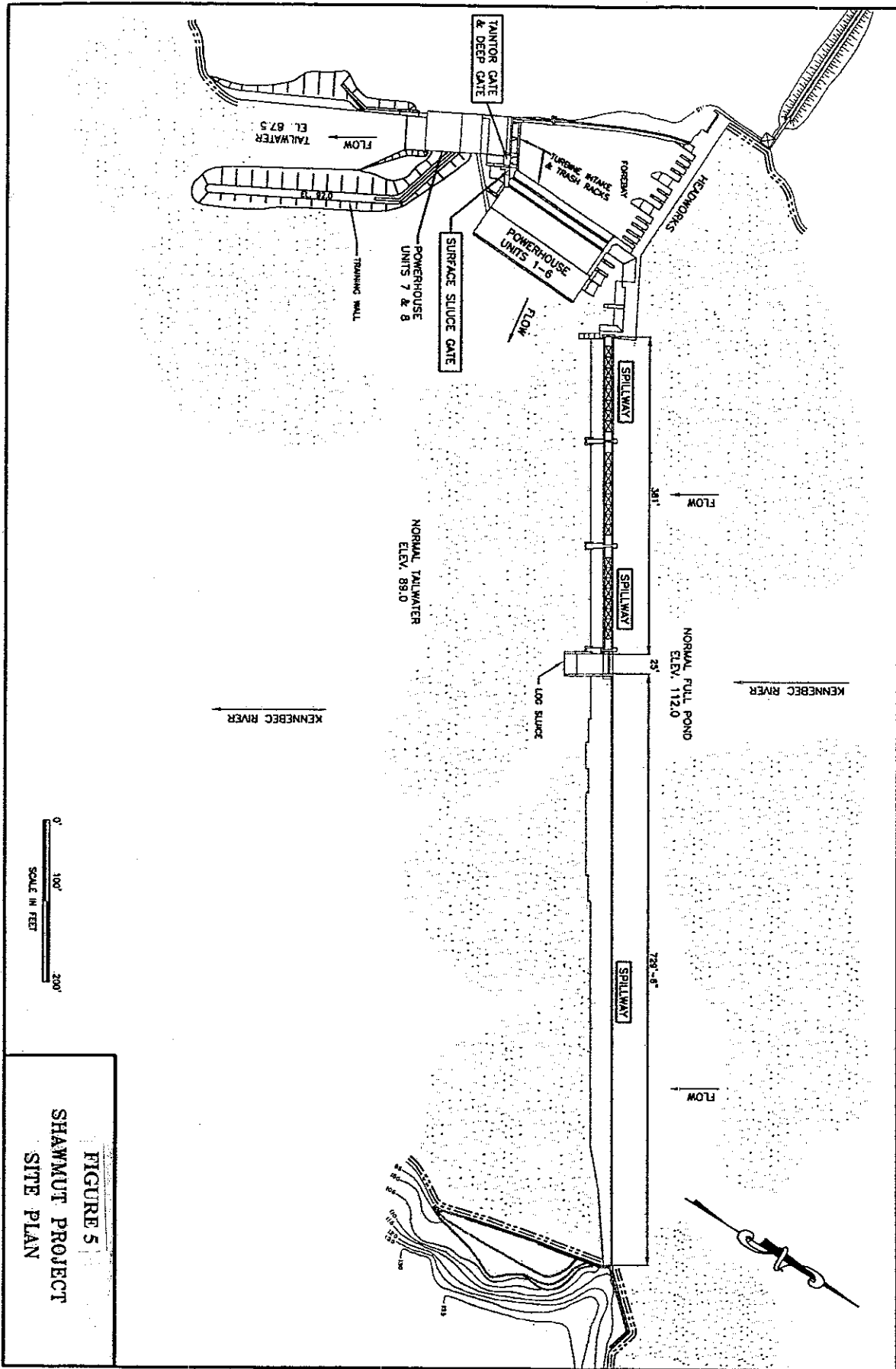

FIGURE 5
SHAMMUT PROJECT
SITE PLAN

0' 100' 200'
SCALE IN FEET

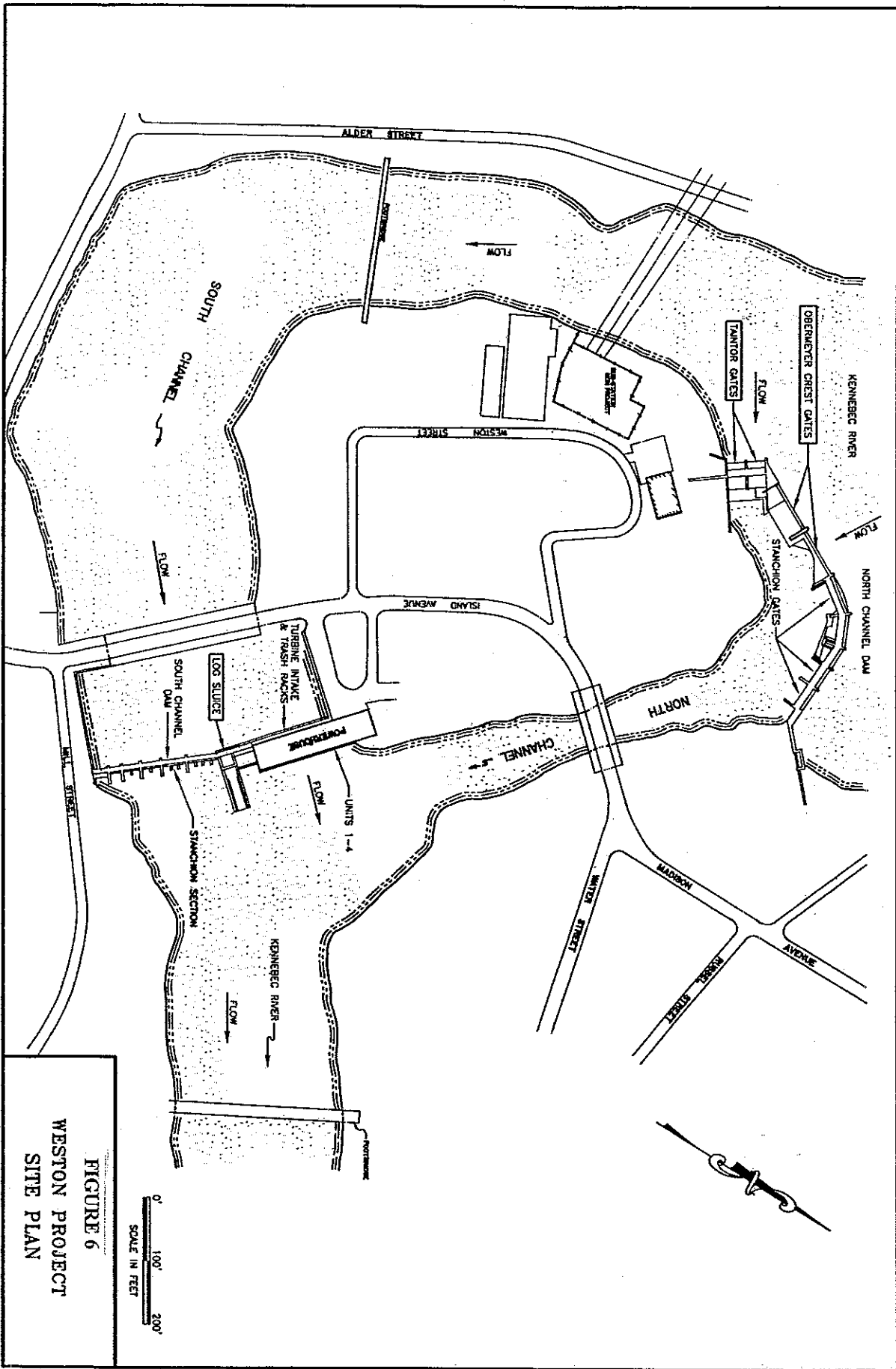

FIGURE 6
WESTON PROJECT
SITE PLAN

0 100' 200'
 SCALE IN FEET

Appendix A:

**River Flow, River Temperature, and Fish Lift
Operational Status at the Lockwood Project**

2008 Diadromous Fish Passage Report

Lockwood Fish Lift River Temperature, River Flow and Fish Lift Status

May 2008

| Date | River Temp. C° | River Flow (cfs) | Fish Lift Status |
|--------|-------------------|---------------------|--------------------|
| 1-May | 7 | 90,000 | Shutdown |
| 2-May | 7 | 65,000 | Shutdown |
| 3-May | 7 | 38,000 | Shutdown |
| 4-May | 7 | 22,000 | Shutdown |
| 5-May | 7.7 | 23,900 | Shutdown |
| 6-May | 8 | 26,090 | Shutdown |
| 7-May | 8.6 | 25,210 | Shutdown |
| 8-May | 9.1 | 22,760 | Operational |
| 9-May | 10.7 | 21,550 | Operational |
| 10-May | 10.3 | 20,740 | Operational |
| 11-May | 10.7 | 19,930 | Operational |
| 12-May | 10.6 | 15,740 | Operational |
| 13-May | 11.9 | 15,140 | Operational |
| 14-May | 12.6 | 12,724 | Operational |
| 15-May | 12.1 | 11,800 | Operational |
| 16-May | 11.8 | 8,717 | Operational |
| 17-May | 12.4 | 8,217 | Operational |
| 18-May | 12.6 | 6,657 | Operational |
| 19-May | 13.9 | 6,487 | Operational |
| 20-May | 15.5 | 6,340 | Shutdown |
| 21-May | 15.5 | 5,757 | Operational |
| 22-May | 14.4 | 5,787 | Operational |
| 23-May | 13.4 | 5,776 | Operational |
| 24-May | 13.1 | 4,554 | Operational |
| 25-May | 13.3 | 5,624 | Operational |
| 26-May | 13.5 | 5,314 | Operational |
| 27-May | 13.4 | 4,914 | Operational |
| 28-May | 14 | 4,743 | Operational |
| 29-May | 14.5 | 4,348 | Operational |
| 30-May | 15.2 | 5,163 | Operational |
| 31-May | 15.5 | 4,267 | Operational |

2008 Diadromous Fish Passage Report

Lockwood Fish Lift River Temperature, River Flow and Fish Lift Status

June 2008

| Date | River Temp. C° | River Flow (cfs) | Fish lift Status |
|-------------|---------------------------|-------------------------|-------------------------|
| 1-Jun | 14.2 | 5,731 | Operational |
| 2-Jun | 15.3 | 5,361 | Operational |
| 3-Jun | 15.9 | 4,637 | Operational |
| 4-Jun | 15.8 | 5,107 | Operational |
| 5-Jun | 14.9 | 5,646 | Operational |
| 6-Jun | 15.2 | 7,316 | Operational |
| 7-Jun | 14.8 | 6,914 | Operational |
| 8-Jun | 16.3 | 6,100 | Operational |
| 9-Jun | 16.2 | 4,974 | Operational |
| 10-Jun | 17.5 | 4,534 | Operational |
| 11-Jun | 17.2 | 6,165 | Operational |
| 12-Jun | 19.4 | 17,390 | Operational |
| 13-Jun | 19.4 | 10,320 | Operational |
| 14-Jun | 19.2 | 9,467 | Operational |
| 15-Jun | 18.8 | 8,968 | Operational |
| 16-Jun | 18.4 | 8,750 | Operational |
| 17-Jun | 17.6 | 11,390 | Operational |
| 18-Jun | 16.5 | 12,445 | Operational |
| 19-Jun | 16.5 | 29,962 | Shutdown |
| 20-Jun | 16.4 | 39,141 | Shutdown |
| 21-Jun | 16.5 | 32,902 | Shutdown |
| 22-Jun | 16.7 | 24,672 | Shutdown |
| 23-Jun | 17 | 23,870 | Shutdown |
| 24-Jun | 17.4 | 18,300 | Operational |
| 25-Jun | 17.6 | 16,620 | Operational |
| 26-Jun | 17.8 | 10,780 | Operational |
| 27-Jun | 19.1 | 10,226 | Operational |
| 28-Jun | 19.9 | 11,685 | Operational |
| 29-Jun | 19.3 | 11,437 | Operational |
| 30-Jun | 18.6 | 14,382 | Operational |

2008 Diadromous Fish Passage Report

Lockwood Fish Lift River Temperature, River Flow and Fish Lift Status

July 2008

| Date | River Temp. C° | River Flow (cfs) | Fish Lift Status |
|-------------|---------------------------|-----------------------------|-------------------------|
| 1-Jul | 18.3 | 29,856 | Shutdown |
| 2-Jul | 18.9 | 16,290 | Operational |
| 3-Jul | 21.3 | 13,840 | Operational |
| 4-Jul | 20 | 13,200 | Operational |
| 5-Jul | 20 | 10,670 | Operational |
| 6-Jul | 20.4 | 8,150 | Operational |
| 7-Jul | 21.3 | 7,680 | Operational |
| 8-Jul | 22.5 | 7,820 | Operational |
| 9-Jul | 22.9 | 7,678 | Operational |
| 10-Jul | 23.5 | 7,013 | Operational |
| 11-Jul | 23 | 5,244 | Operational |
| 12-Jul | 22.8 | 6,455 | Operational |
| 13-Jul | 22.8 | 5,452 | Operational |
| 14-Jul | 22.5 | 5,049 | Operational |
| 15-Jul | 22.9 | 5,759 | Operational |
| 16-Jul | 22.9 | 7,258 | Operational |
| 17-Jul | 23.1 | 5,868 | Operational |
| 18-Jul | 23.8 | 5,025 | Operational |
| 19-Jul | 23.4 | 4,500 | Operational |
| 20-Jul | 24.5 | 3,643 | Operational |
| 21-Jul | 22.9 | 8,199 | Operational |
| 22-Jul | 23.2 | 10,944 | Operational |
| 23-Jul | 23.3 | 8,238 | Operational |
| 24-Jul | 22.6 | 7,656 | Operational |
| 25-Jul | 22.2 | 22,530 | Shutdown |
| 26-Jul | 22.3 | 24,766 | Shutdown |
| 27-Jul | 21.9 | 14,793 | Operational |
| 28-Jul | 21.5 | 12,500 | Operational |
| 29-Jul | 22.4 | 9,329 | Operational |
| 30-Jul | 22.4 | 7,832 | Operational |
| 31-Jul | 23 | 3,021 | Operational |

2008 Diadromous Fish Passage Report

Lockwood Fish Lift River Temperature, River Flow and Fish Lift Status

August 2008

| Date | River Temp. C° | River Flow (cfs) | Fish Lift Status |
|-------------|---------------------------|-----------------------------|--------------------------------|
| 1-Aug | 22.4 | 9,563 | Operational |
| 2-Aug | 22 | 11,250 | Operational |
| 3-Aug | 22.2 | 10,656 | Operational |
| 4-Aug | 22.1 | 12,461 | Annual 2-week Station Shutdown |
| 5-Aug | 22.3 | 13,255 | Annual 2-week Station Shutdown |
| 6-Aug | 22.2 | 13,362 | Annual 2-week Station Shutdown |
| 7-Aug | 22.2 | 17,282 | Annual 2-week Station Shutdown |
| 8-Aug | 21.5 | 41,680 | Annual 2-week Station Shutdown |
| 9-Aug | 20.6 | 48,500 | Annual 2-week Station Shutdown |
| 10-Aug | 20 | 43,100 | Annual 2-week Station Shutdown |
| 11-Aug | 19.5 | 30,000 | Annual 2-week Station Shutdown |
| 12-Aug | 19.2 | 25,000 | Annual 2-week Station Shutdown |
| 13-Aug | 19 | 20,600 | Annual 2-week Station Shutdown |
| 14-Aug | 19 | 13,390 | Annual 2-week Station Shutdown |
| 15-Aug | 19.9 | 12,280 | Operational |
| 16-Aug | 20.3 | 11,910 | Operational |
| 17-Aug | 20.3 | 13,910 | Operational |
| 18-Aug | 20.5 | 12,690 | Operational |
| 19-Aug | 20.6 | 11,680 | Operational |
| 20-Aug | 19.8 | 10,591 | Shutdown |
| 21-Aug | 19.9 | 10,455 | Shutdown |
| 22-Aug | 20 | 10,167 | Operational |
| 23-Aug | 20.3 | 10,113 | Operational |
| 24-Aug | 20.2 | 10,011 | Operational |
| 25-Aug | 20.5 | 9,430 | Operational |
| 26-Aug | 20.4 | 9,152 | Operational |
| 27-Aug | 20.9 | 10,500 | Operational |
| 28-Aug | 20.5 | 4,752 | Operational |
| 29-Aug | 20.6 | 3,324 | Operational |
| 30-Aug | 21 | 3,875 | Operational |
| 31-Aug | 20.9 | 7,122 | Operational |

2008 Diadromous Fish Passage Report

Lockwood Fish Lift River Temperature, River Flow and Fish Lift Status

September 2008

| Date | River Temp. C° | River Flow (cfs) | Fish Lift Status |
|-------------|---------------------------|-----------------------------|-------------------------|
| 1-Sep | 20.8 | 7,224 | Operational |
| 2-Sep | 20.9 | 7,036 | Operational |
| 3-Sep | 21.2 | 7,675 | Operational |
| 4-Sep | 21.2 | 4,301 | Operational |
| 5-Sep | 21.6 | 4,291 | Operational |
| 6-Sep | 21.6 | 3,800 | Operational |
| 7-Sep | 21 | 8,372 | Operational |
| 8-Sep | 20.9 | 11,754 | Operational |
| 9-Sep | 20.8 | 7,576 | Operational |
| 10-Sep | 20.5 | 8,900 | Operational |
| 11-Sep | 18.8 | 8,240 | Operational |
| 12-Sep | 18.8 | 8,100 | Operational |
| 13-Sep | 18.9 | 6,900 | Operational |
| 14-Sep | 18.7 | 6,900 | Operational |
| 15-Sep | 18.8 | 7,250 | Operational |
| 16-Sep | 18.7 | 6,140 | Operational |
| 17-Sep | 18.4 | 5,550 | Operational |
| 18-Sep | 18.6 | 6,010 | Operational |
| 19-Sep | 18.1 | 5,150 | Operational |
| 20-Sep | 17.9 | 4,720 | Operational |
| 21-Sep | 17.3 | 4,721 | Operational |
| 22-Sep | 17.2 | 7,170 | Operational |
| 23-Sep | 17.2 | 5,082 | Shutdown |
| 24-Sep | 15.8 | 4,677 | Shutdown |
| 25-Sep | 15.9 | 5,056 | Shutdown |
| 26-Sep | 16.3 | 5,056 | Shutdown |
| 27-Sep | 16.9 | 4,259 | Shutdown |
| 28-Sep | 17.4 | 8,339 | Shutdown |
| 29-Sep | 17 | 21,600 | Shutdown |
| 30-Sep | 16 | 14,930 | Shutdown |

2008 Diadromous Fish Passage Report

Lockwood Fish Lift River Temperature, River Flow and Fish Lift Status

October 2008

| Date | River Temp. C° | River Flow (cfs) | Fish Lift Status |
|-------------|---------------------------|-----------------------------|-------------------------|
| 1-Oct | 16.2 | 11,430 | Operational |
| 2-Oct | 16 | 9,520 | Operational |
| 3-Oct | 15.2 | 9,370 | Operational |
| 4-Oct | 14.8 | 8,300 | Operational |
| 5-Oct | 14.1 | 8,300 | Operational |
| 6-Oct | 13.6 | 6,290 | Operational |
| 7-Oct | 12.8 | 7,110 | Operational |
| 8-Oct | 12.6 | 6,270 | Operational |
| 9-Oct | 13 | 6,045 | Operational |
| 10-Oct | 13.3 | 5,250 | Operational |
| 11-Oct | 13.3 | 6,220 | Operational |
| 12-Oct | 12.9 | 4,814 | Operational |
| 13-Oct | 13.4 | 5,109 | Operational |
| 14-Oct | 13.3 | 5,946 | Operational |
| 15-Oct | 13.3 | 5,051 | Operational |
| 16-Oct | 13.3 | 5,094 | Operational |
| 17-Oct | 13.1 | 6,160 | Operational |
| 18-Oct | 13 | 5,933 | Operational |
| 19-Oct | 12.7 | 5,842 | Operational |
| 20-Oct | 12.2 | 8,769 | Operational |
| 21-Oct | 11.7 | 6,391 | Operational |
| 22-Oct | 10.9 | 5,236 | Operational |
| 23-Oct | 10.1 | 5,162 | Operational |
| 24-Oct | 9.2 | 4,819 | Operational |
| 25-Oct | 9 | 4,762 | Operational |
| 26-Oct | 10 | 5,000 | Operational |
| 27-Oct | 10.3 | 32,660 | Shutdown |
| 28-Oct | 10.2 | 18,520 | Operational |
| 29-Oct | 9.9 | 15,730 | Operational |
| 30-Oct | 9.3 | 16,340 | Operational |
| 31-Oct | 8.9 | 13,890 | Operational |

Appendix B:

**Evaluation of Silver American Eel Downstream
Passage at the
Shawmut Project
(Kennebec River, Maine)**

Appendix C:

**Evaluation of Silver American Eel Downstream
Passage at the
Weston Project
(Kennebec River, Maine)**